

ASSEMBLY INSTRUCTIONS

# Bar Table

EEl-7593 / V0.11.11.25

---

**modway**



Questions? Contact us!

609.256.9000

[cs@modway.com](mailto:cs@modway.com)

# Welcome.

## Let's get started.

Before you begin, here are some things to keep in mind:

Assembly will take most people **about 30 minutes**. Consider having a friend help you!

**Only use hand tools to assemble this item.** Do not use power tools. Do not tighten bolts or screws completely until all hardware is lined up and inserted into the holes.

**Read through all of the instructions before starting. Make sure you have all parts and components before discarding any packing materials.**





Do not over-tighten screws and bolts to avoid stripping the hardware or cracking the item.

Assemble your item on a flat, carpeted area, with plenty of space to work. This will prevent damage and scratches to your floors or the item while you're assembling the product.

Keep all components and packaging out of reach of children or animals to avoid risk of choking or suffocation.

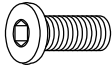
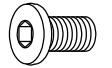
**Care instructions are listed in the last step of this manual.**

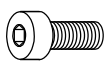
## HARDWARE INCLUDED IN THE BOX:

D		JCBC Bolt M6 x 30mm (1PC for spare parts)	x7
E		JCBC Bolt M6 x 25mm (1PC for spare parts)	x3
F		Allen Wrench 4mm	x1
H		JCBC Bolt M6 x 20mm (1PC for spare parts)	x5
I		Allen Wrench 5mm	x1
J		Flat Washer 16mm x 6.5mm (1PC for spare parts)	x9

## FURNITURE COMPONENTS:

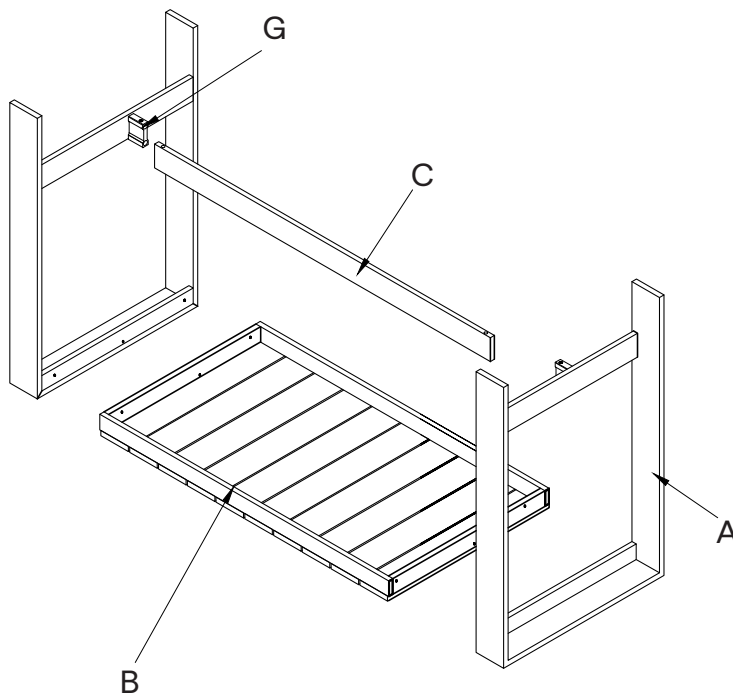

A	Table Leg	x2
B	Table Top	x1
C	Center Support Rail	x1
G	Support Post	x2

WAIT!

Missing parts or hardware? Need assistance?  
Contact us before returning your item.  
We're here to help!



**HARDWARE**

**H** JCBC Bolt M6 x 20mm X4

**I** Allen Wrench 5mm X1

**COMPONENTS**

**A** Table Leg X2

**G** Support Post X2

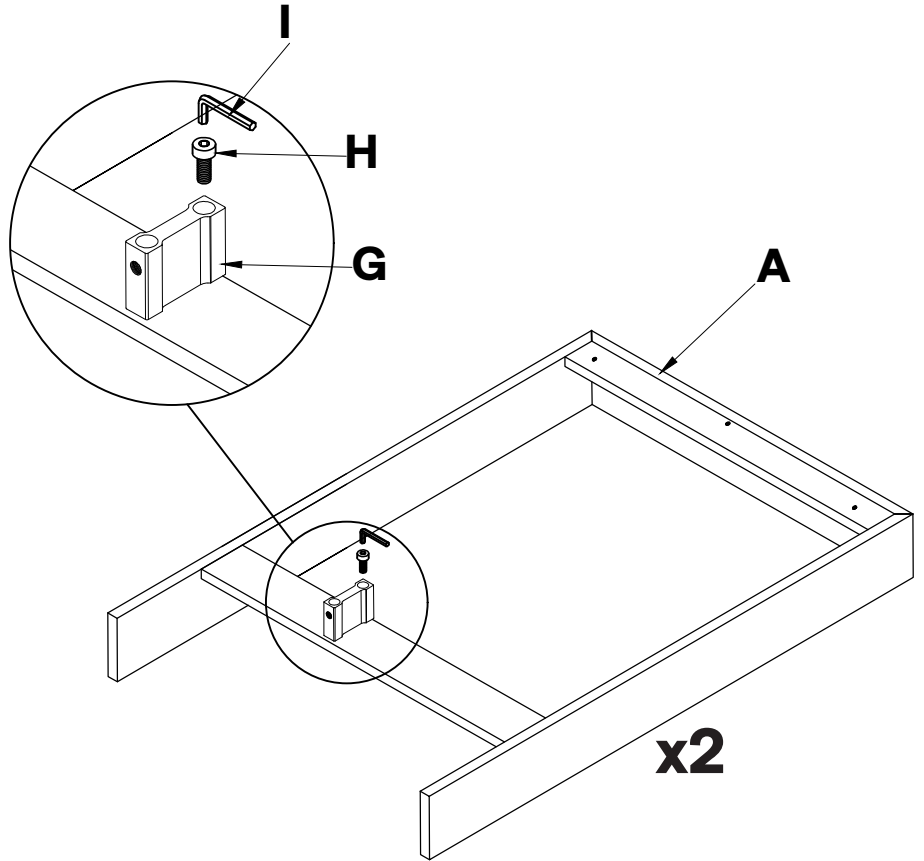

STEP 02

**HARDWARE**

**D** JCBC Bolt M6 x 30mm X3

**F** Allen Wrench 4mm X1

**J** Flat Washer 16mm x 6.5mm X3

**COMPONENTS**

**A** Table Leg X1

**B** Table Top X1

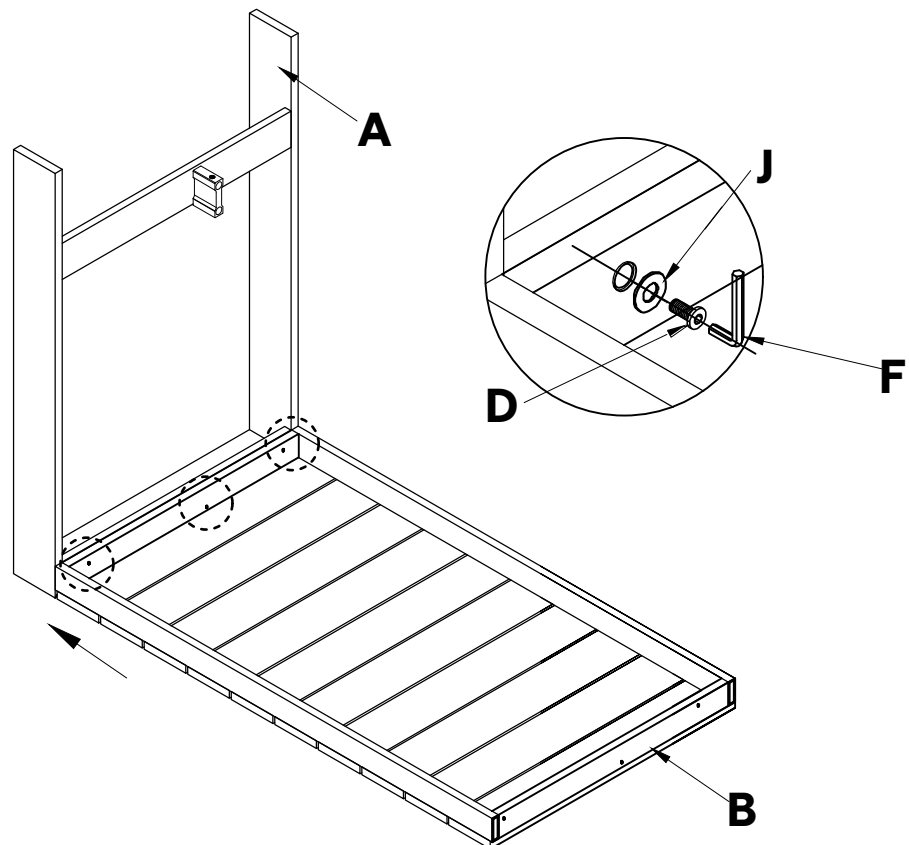

**HARDWARE**

- E** JCBC Bolt M6 x 25mm Allen X1
- F** Wrench 4mm X1
- J** Flat Washer 16mm x 6.5mm X1

**COMPONENTS**

- A** Table Leg X1
- B** Table Top X1
- C** Center Support Rail X1

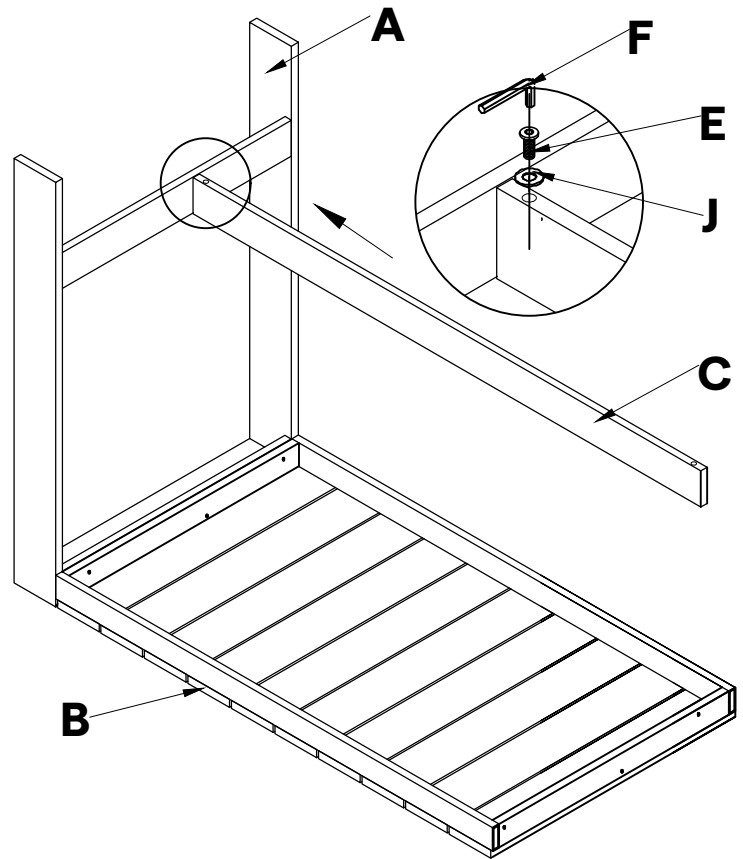

STEP 04

**HARDWARE**

- D** JCBC Bolt M6 x 30mm X3
- E** JCBC Bolt M6 x 25mm X1
- F** Allen Wrench 4mm X1
- J** Flat Washer 16mm x 6.5mm X4

**COMPONENTS**

- A** Table Leg X1
- B** Table Top X1

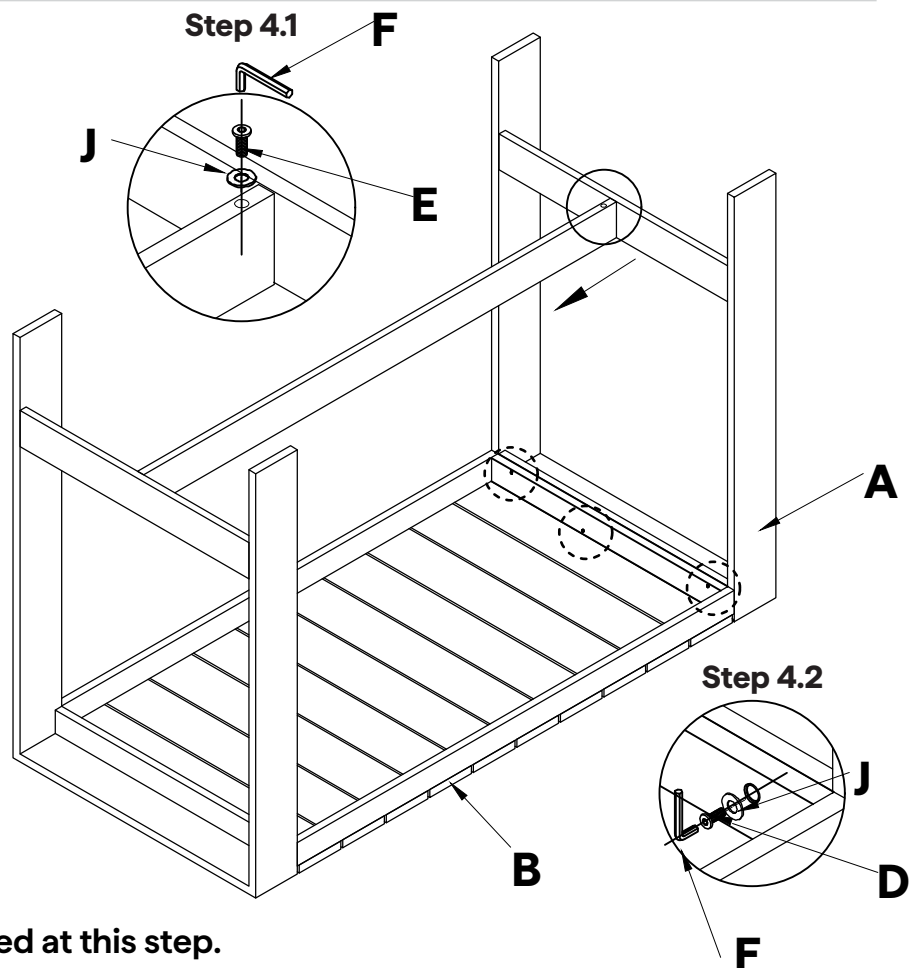

**NOTE: All bolts must be fully tightened at this step.**

# Great job!

Your new table is complete.

## CARING FOR YOUR ITEM

- Depending on use, it may be necessary to tighten the hardware from time to time, so please save the tools that have been provided.
- Not contract grade.
- Clean using a non-abrasive cloth and a mild cleaner.

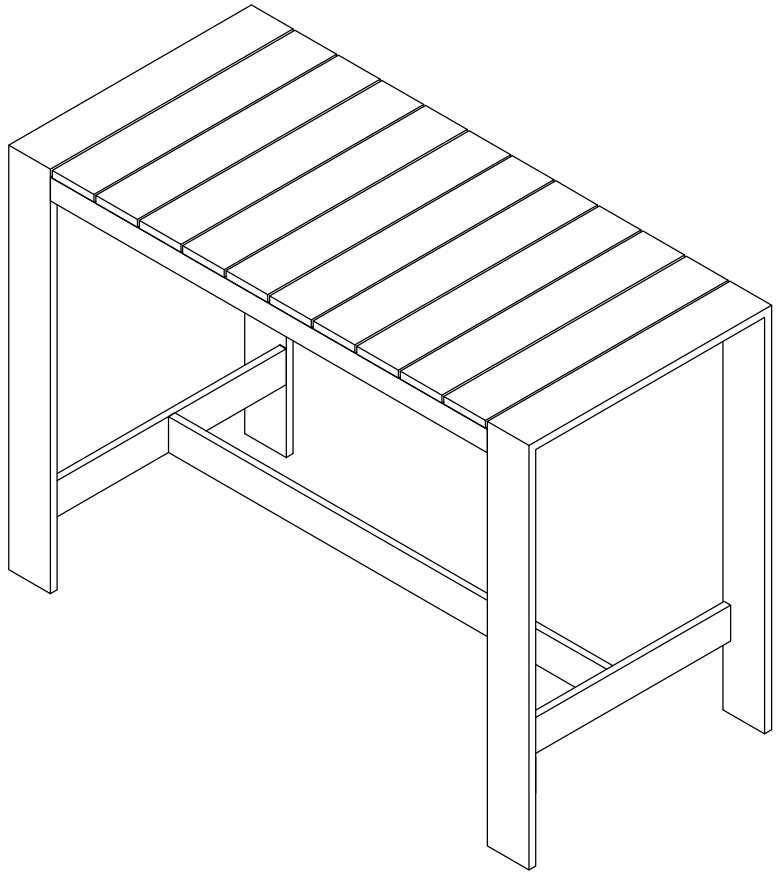

## CONNECT WITH US!

Tag us [@modway\\_furniture](#) and [#modway](#) for a chance to be featured.

# modway



Questions? Contact us!  
609.256.9000  
[cs@modway.com](mailto:cs@modway.com)