

ASSEMBLY INSTRUCTIONS

# Bar Table

EEl-7585 / V0.15.11.25

---

**modway**



Questions? Contact us!

609.256.9000

[cs@modway.com](mailto:cs@modway.com)

# Welcome.

## Let's get started.

Before you begin, here are some things to keep in mind:

Assembly will take most people **about 30 minutes**. Consider having a friend help you!

**Only use hand tools to assemble this item.** Do not use power tools. Do not tighten bolts or screws completely until all hardware is lined up and inserted into the holes.

**Read through all of the instructions before starting. Make sure you have all parts and components before discarding any packing materials.**

Do not over-tighten screws and bolts to avoid stripping the hardware or cracking the item.

Assemble your item on a flat, carpeted area, with plenty of space to work. This will prevent damage and scratches to your floors or the item while you're assembling the product.

Keep all components and packaging out of reach of children or animals to avoid risk of choking or suffocation.



**Care instructions are listed in the last step of this manual.**

**WAIT!**

**Missing parts or hardware? Need assistance?**  
Contact us before returning your item.  
We're here to help!



## HARDWARE INCLUDED IN THE BOX:

<b>A</b>		Bolt M8 x 30mm	x12
<b>B</b>		Spring Washer M8	x12
<b>C</b>		Allen Key M4	x1

# FURNITURE COMPONENTS INCLUDED IN THE BOX:

All parts are numbered with a sticker according to this list.

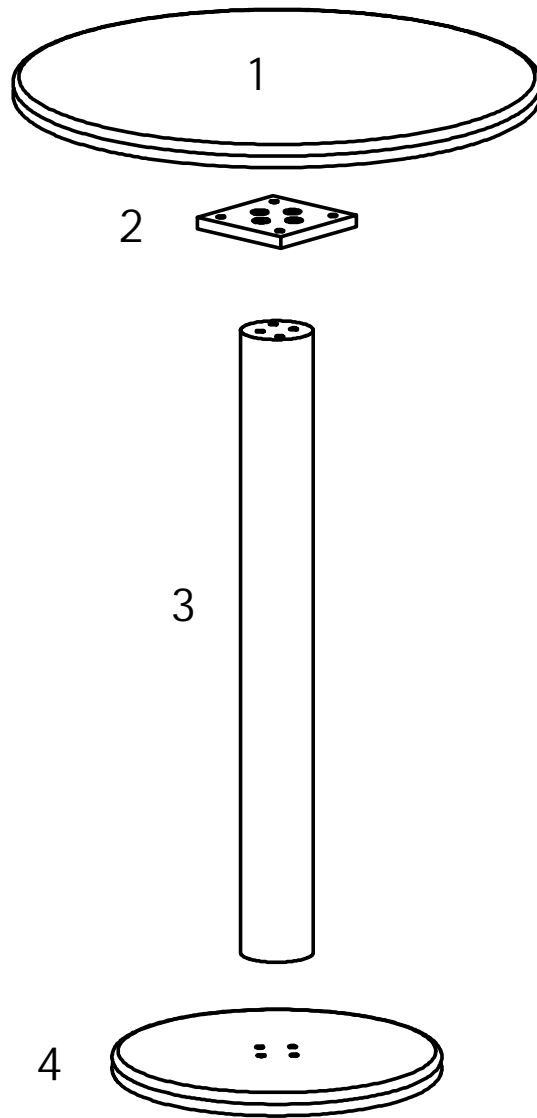

---

1 Table Top x1

2 Mounting Plate x1

3 Leg x1

---

4 Base x1

---

## STEP 01

### HARDWARE

**A** Bolt M8 x 30mm x4

**B** Spring Washer M8 x4

### COMPONENTS

**2** Mounting Plate x1

**3** Leg x1

### TOOLS

**C** Allen Key x1

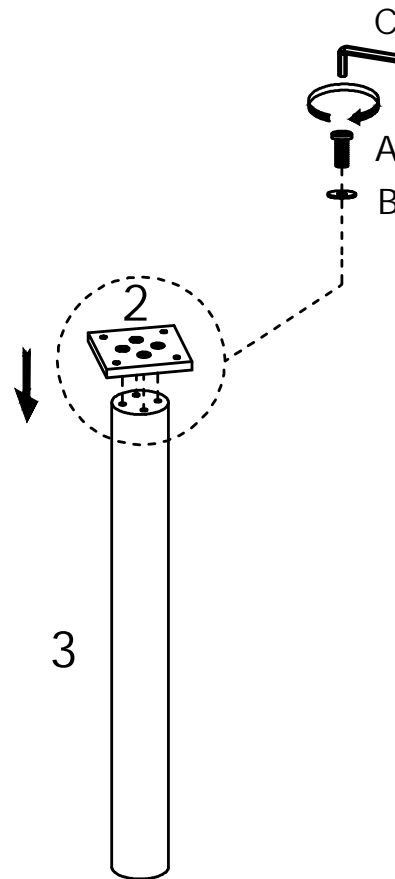

- 1.1 Assemble Mounting Plates (2) onto the Leg (3) by inserting Bolt M8x30mm (A) together with Spring Washer (B) into the mounting holes, then tighten all screws to 100% using the Allen Key (C)

## STEP 02

### HARDWARE

**A** Bolt M8 x 30mm x4

**B** Spring Washer M8 x4

### COMPONENTS

**4** Base x1

### TOOLS

**C** Allen Key x1

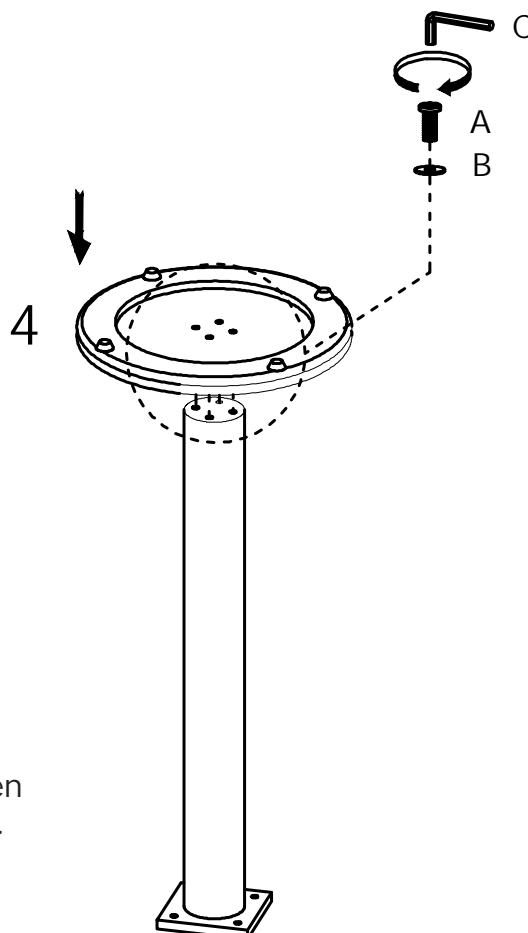

- 2.1 Attach the Base (4) to the top of the Leg by inserting Bolt M8x30mm (A) together with Spring Washer (B) into each mounting hole, then fully tighten all bolts using the Allen Key (C) as shown.

## HARDWARE

**A** Bolt M8 x 30mm x4

**B** Spring Washer M8 x4

## COMPONENTS

**1** Table Top x1

## TOOLS

**C** Allen Key x1

- 4.1 Attach the Table Top (1) by inserting Bolt M8x30mm (A) together with Spring Washer (B) into the mounting holes, then fully tighten all bolts using the Allen Key (C) as shown.

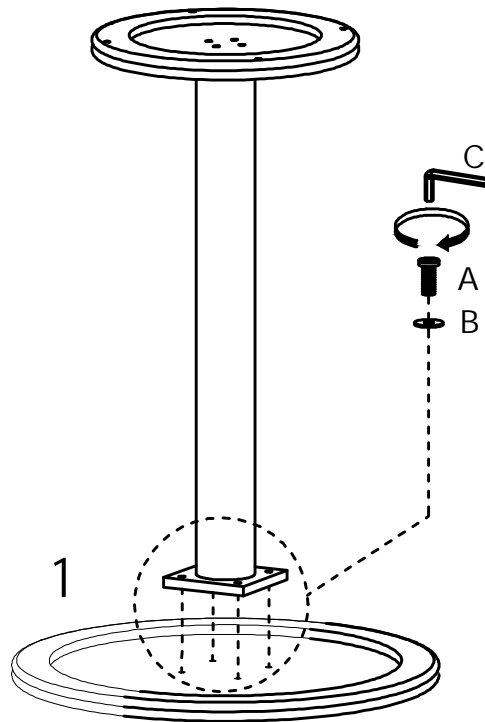

## STEP 04

- 4.1 With help, flip the Bar Table upright. To level the table, reach the leveler under the leg and adjust accordingly.

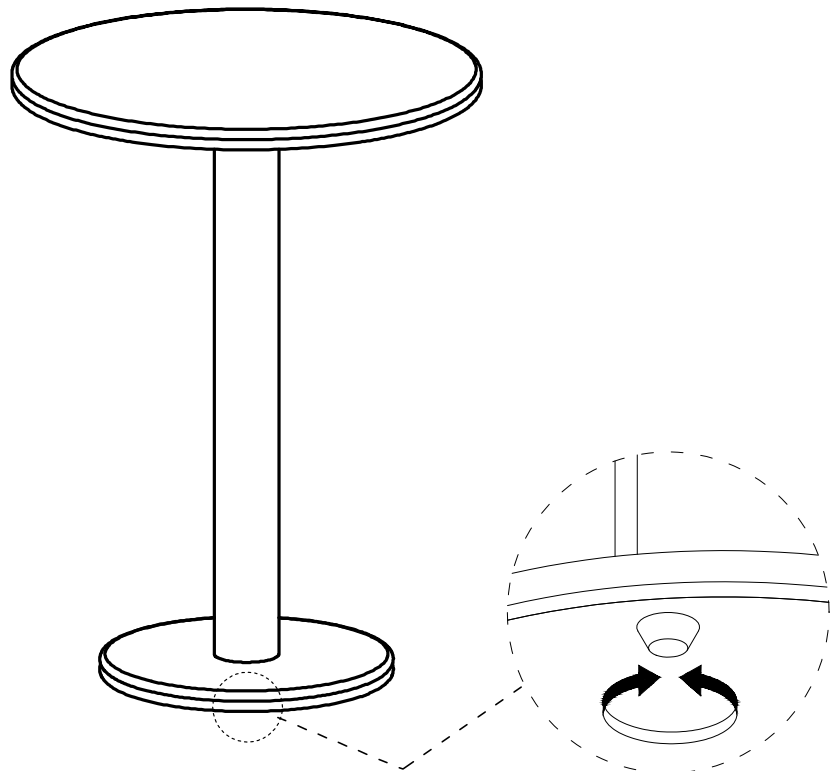

# Great job!

Bar Table assembly is completed and ready for using.

## CARING FOR YOUR ITEM

- Not contract grade.
- Clean using a non-abrasive cloth and a mild cleaner.
- Never use harsh chemicals, as they could damage the finish or integrity of the item.

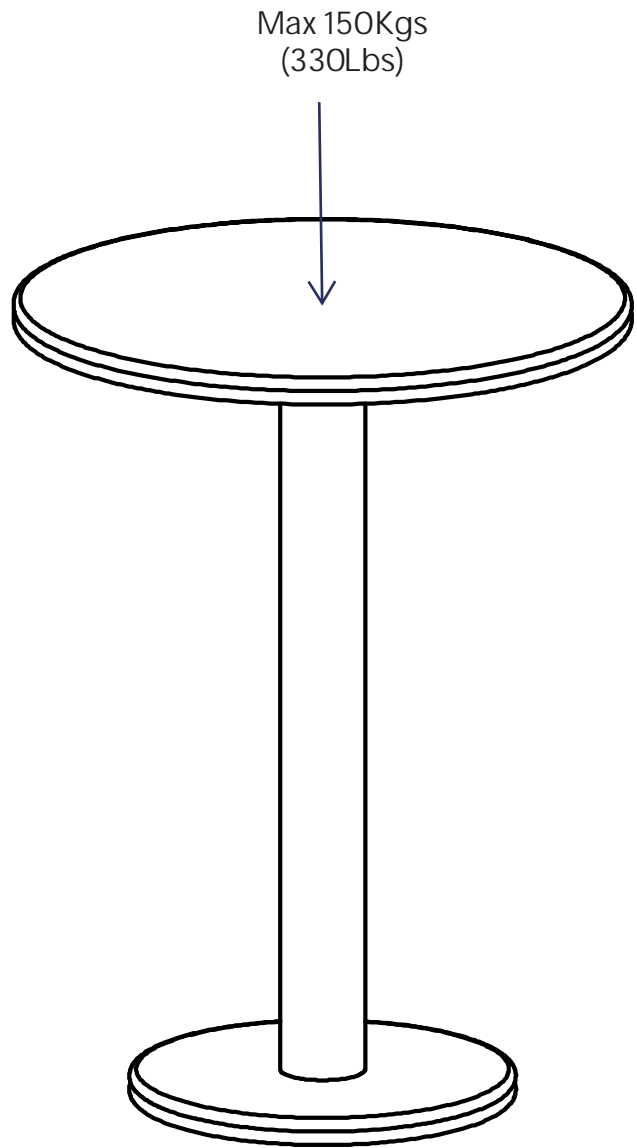

## CONNECT WITH US!

Tag us [@modway\\_furniture](#) and [#modway](#) for a chance to be featured.

# modway



Questions? Contact us!  
609.256.9000  
[cs@modway.com](mailto:cs@modway.com)