

ASSEMBLY INSTRUCTIONS

EEI-6254

V2.04.16.24

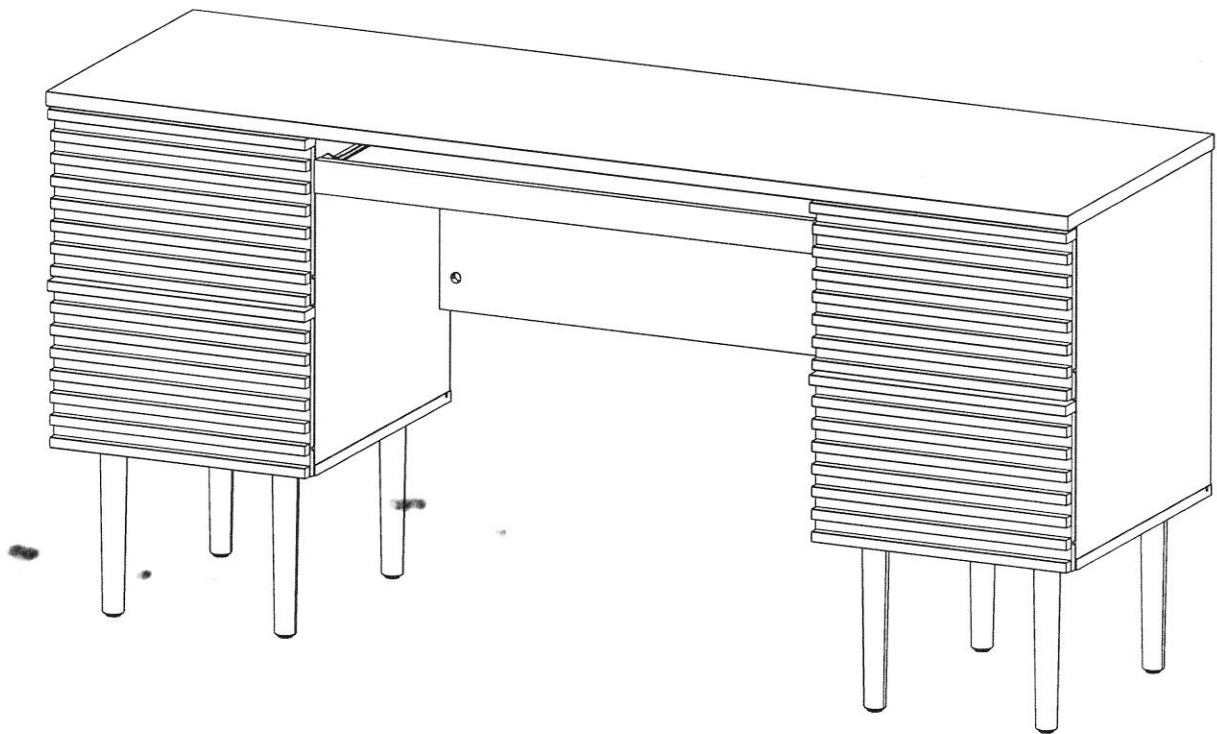

Questions? Contact us!

609.256.9000 • cs@modway.com
www.modway.com

***modway**



Read through all of the instructions before starting



Care instructions are listed in the last step of this manual



Approx. 60 minutes assembly time



Make sure you have all parts and components before discarding any packing materials



2 people recommended for assembly

Only use hand tools to assemble this item. Do not use power tools. Do not tighten bolts or screws completely until all hardware is lined up and inserted into the holes.

Do not over-tighten screws and bolts to avoid stripping the hardware or cracking the item.

Assemble your item on a flat, carpeted area, with plenty of space to work. This will prevent damage and scratches to your floors or the item while you're assembling the product.

Keep all components and packaging out of reach of children or animals to avoid risk of choking or suffocation.

Furniture components:



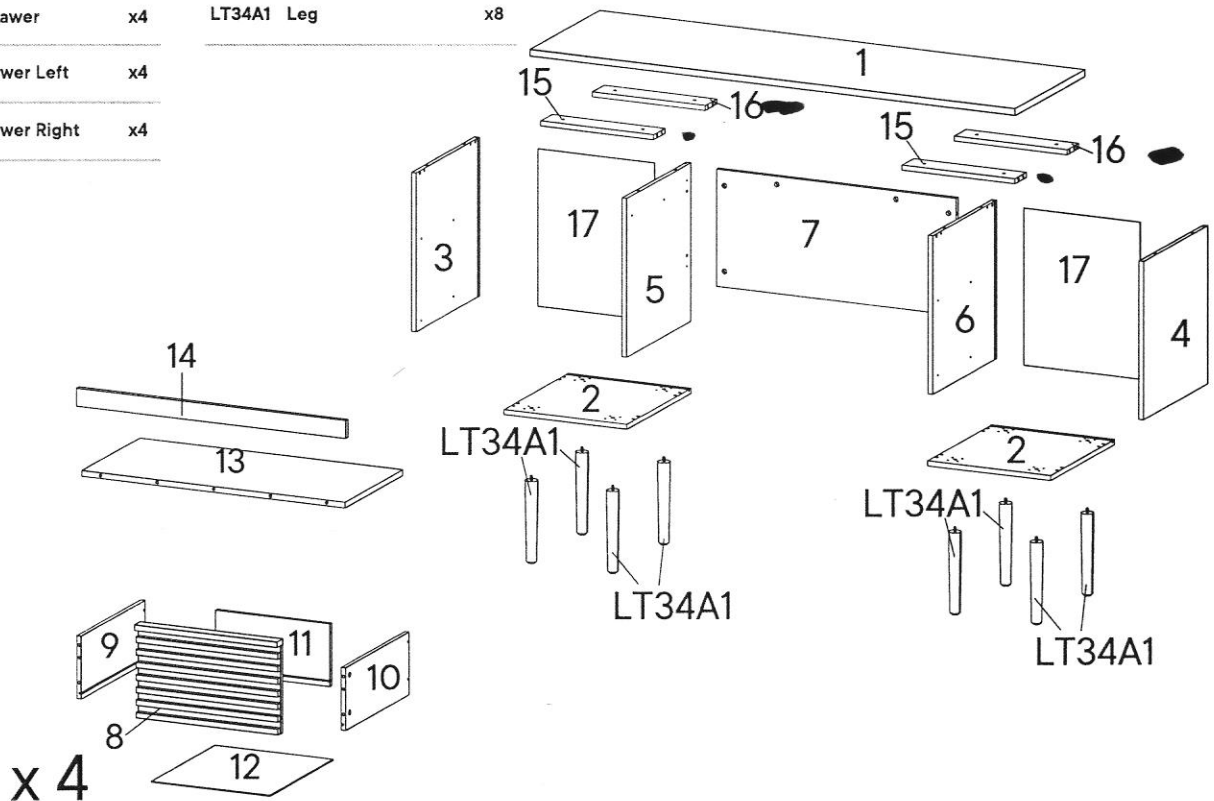















1	Top Board	x1	11	Back Drawer	x4
2	Bottom Board	x2	12	Bottom Drawer	x4
3	Side Board Left	x1	13	Keyboard Base Drawer	x1
4	Side Board Right	x1	14	Front Skirt	x1
5	Center Board 1	x1	15	Support Board 1	x2
6	Center Board 2	x1	16	Support Board 2	x2
7	Back Board 1	x1	17	Back Board 2	x2
8	Front Drawer	x4	LT34A1	Leg	x8
9	Side Drawer Left	x4			
10	Side Drawer Right	x4			



Wait!

Missing parts or hardware? Need assistance?
Contact us before returning your item. We're here to help!
609.256.9000 • cs@modway.com

Provided hardware:

A		Cam Bolt Ø6 x 35 mm	x17	J		Allen Key	x2
B		Cam Lock Ø15 mm	x17	K		Screw M 8 x 39 mm	x16
C		Cam Lock Ø12 mm	x16	L		Screw M 3.5 x 13 mm	x30
D		Cam Bolt Ø6 x 32 mm	x16	M		Screw M 6.4 x 25 mm	x8
E		Wood Dowel Ø8 x 30 mm	x32	N		Screw M 6 x 10.5 mm	x20
F		Wood Dowel Ø6 x 30 mm	x8	O		Screw Cap Ø15 mm	x6
G		Screw M 3.5 x 15.5 mm	x24	P		Wedge	x24
H		Screw M 4.5 x 12.5 mm	x32	PM3		Mounting Plate	x8
I		Screw M 7 x 50 mm	x8	RM35A		Drawer Runner	x5

What you need:

 Phillips Head Screwdriver

Components Carton Placement

Carton 1 of 2

Label	Description	Qty
2	Bottom Board	x2
3	Side Board Left	x1
4	Side Board Right	x1
5	Center Board 1	x1
6	Center Board 2	x1
9	Side Drawer Left	x4
10	Side Drawer Right	x4
11	Back Drawer	x4
12	Bottom Drawer	x4
17	Back Board 2	x2
LT34A1	Leg	x4
	Hardware Pack	x1

Carton 2 of 2

Label	Description	Qty
1	Top Board	x1
7	Back Board 1	x1
8	Front Drawer	x4
13	Keyboard Base Drawer	x1
14	Front Skirt	x1
15	Support Board 1	x2
16	Support Board 2	x2

Wait!

Missing parts or hardware? Need assistance?
Contact us before returning your item. We're here to help!
609.256.9000 • cs@modway.com

Step 1

HARDWARE

- D** Cam Bolt Ø6 x 32 mm x16
- F** Wood Dowel Ø6 x 30 mm x8

COMPONENTS

- 8** Front Drawer x4
- 9** Side Drawer Left x4
- 10** Side Drawer Right x4

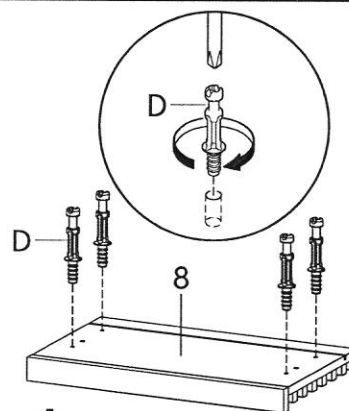
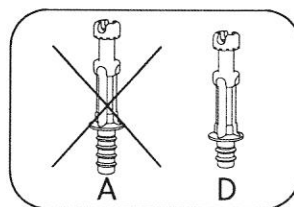

x 4

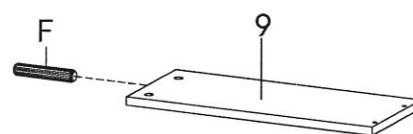

x 4

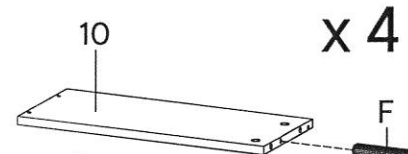

x 4

Step 2

HARDWARE

- C** Cam Lock Ø12 mm x16
- K** Screw M 8 x 39 mm x16

COMPONENTS

- 8** Front Drawer x4
- 9** Side Drawer Left x4
- 10** Side Drawer Right x4
- 11** Back Drawer x4
- 12** Bottom Drawer x4

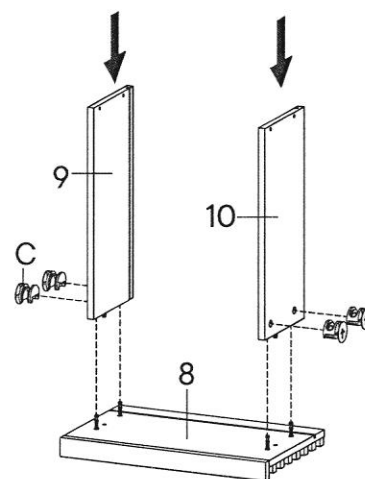
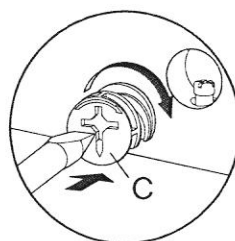

x 4

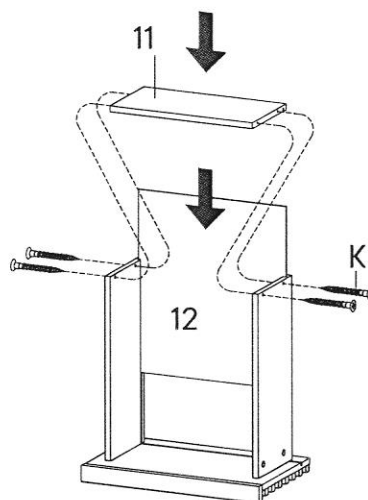

x 4

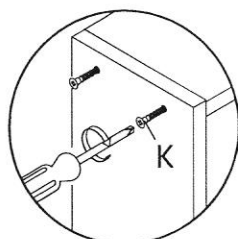

Step 3

HARDWARE

G	Screw M 3.5 x 15.5 mm	x16
L	Screw M 3.5 x 13 mm	x24
P	Wedge	x16
RM35A	Drawer Runner	x4

RM35A (DR)

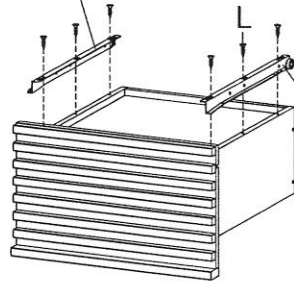

x 4

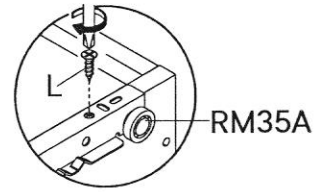

RM35A (DL)

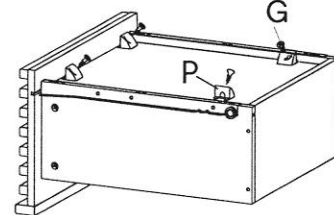
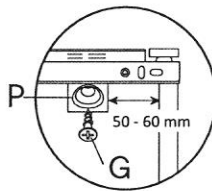
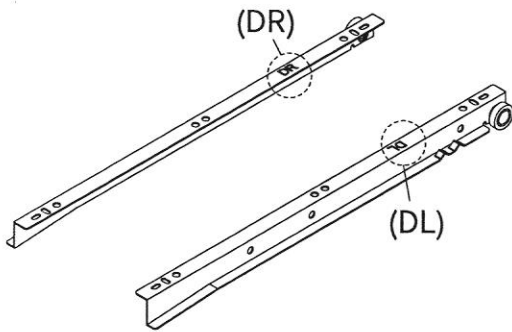
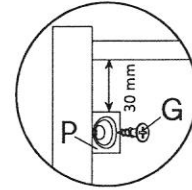

x 4

Step 4

HARDWARE

A	Cam Bolt $\varnothing 6$ x 35 mm	x4
E	Wood Dowel $\varnothing 8$ x 30 mm	x16
N	Screw M 6 x 10.5 mm	x8
RM35A	Drawer Runner	x2

COMPONENTS

3	Side Board Left	x1
4	Side Board Right	x1
15	Support Board 1	x2
16	Support Board 2	x2

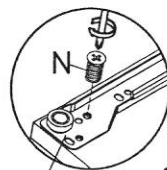
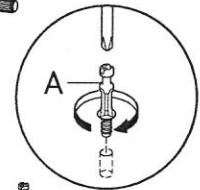
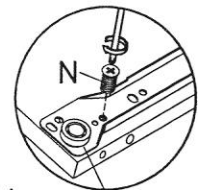
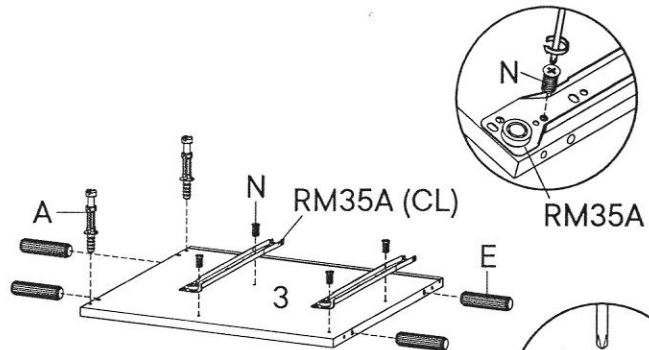

RM35A

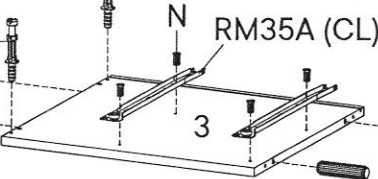

RM35A (CR)

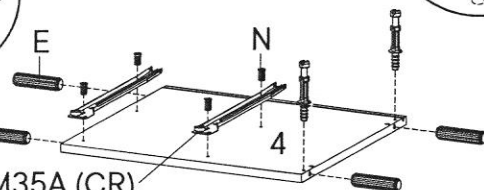

x 2

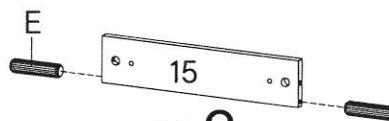

x 2

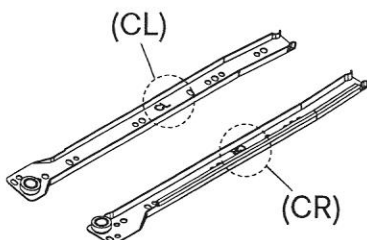
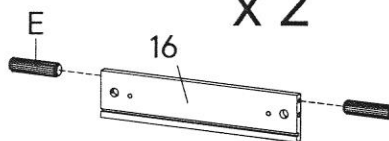

Step 5

HARDWARE

A	Cam Bolt Ø6 x 35 mm	x4
E	Wood Dowel Ø8 x 30 mm	x8
N	Screw M 6 x 10.5 mm	x12
RM35A	Drawer Runner	x3

COMPONENTS

5	Center Board 1	x1
6	Center Board 2	x1

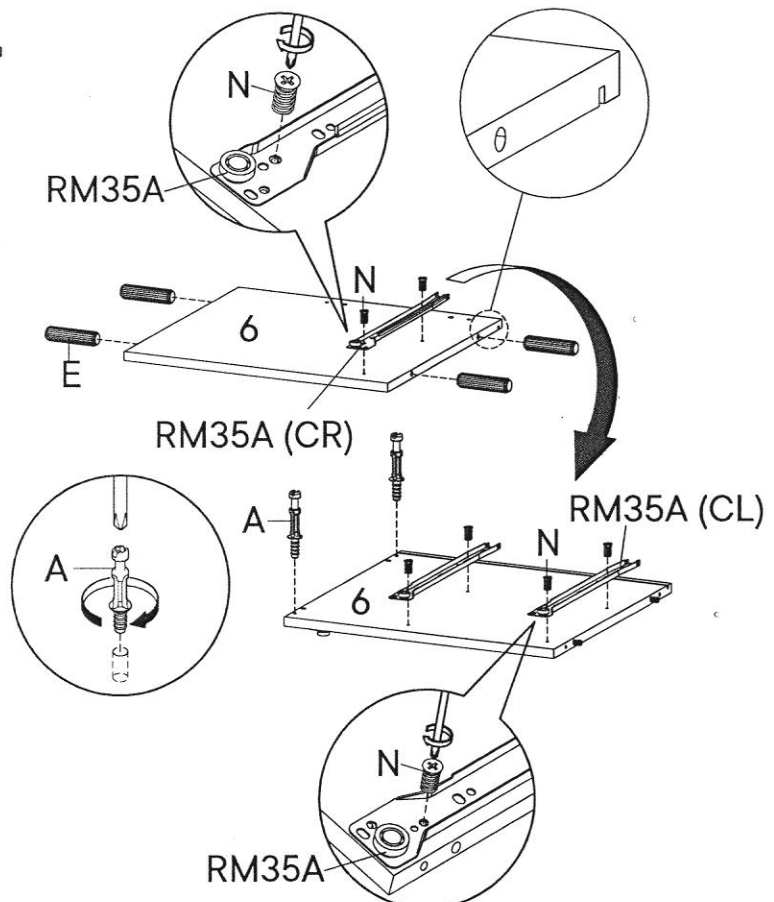
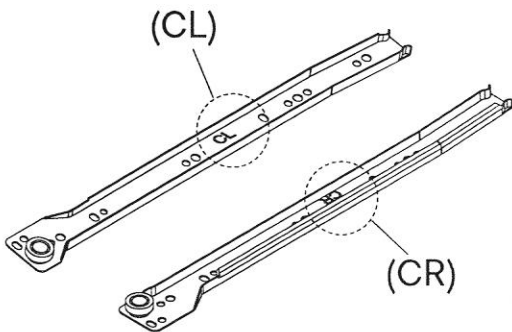
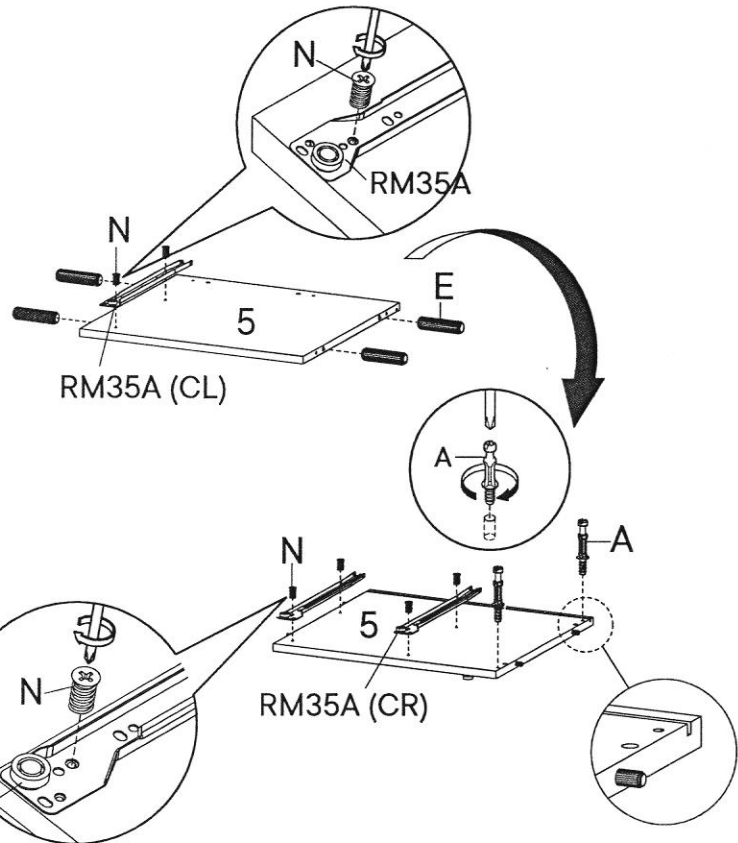

Step 6

HARDWARE

H Screw M 4.5 x 12.5 mm x32

PM3 Mounting Plate x8

COMPONENTS

2 Bottom Board x2

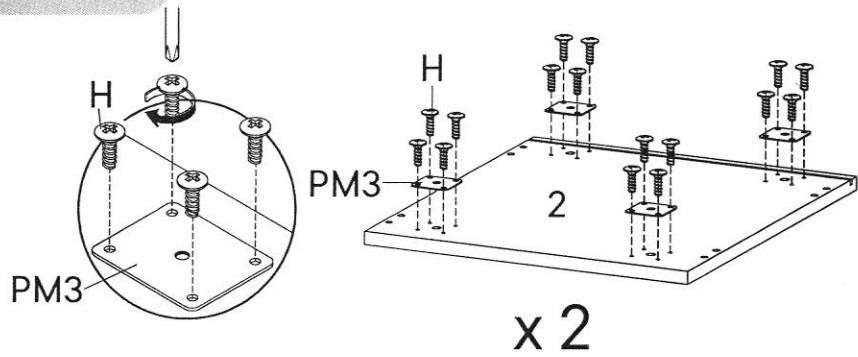
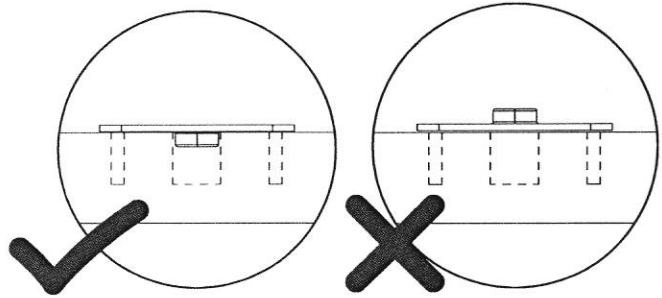

Step 7

HARDWARE

B Cam Lock Ø15 mm x8

COMPONENTS

3 Side Board Left x1

4 Side Board Right x1

5 Center Board 1 x1

6 Center Board 2 x1

15 Support Board 1 x2

16 Support Board 2 x2

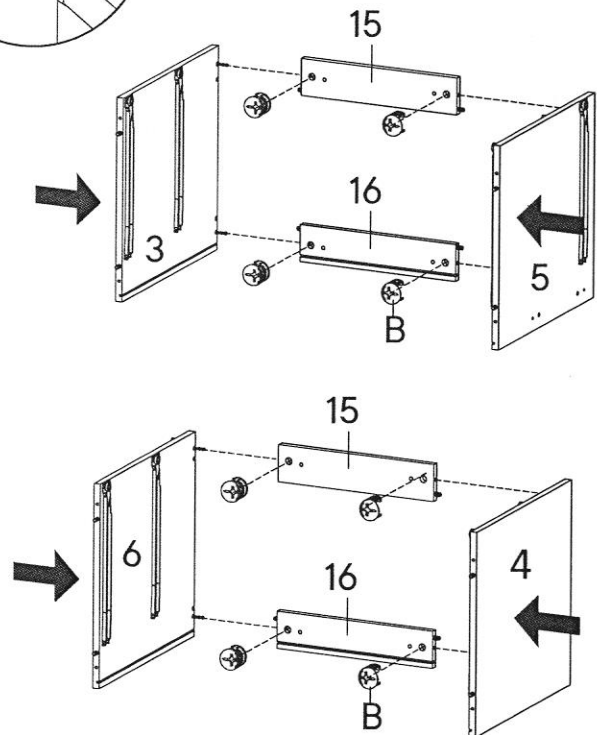
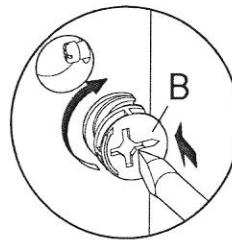

Step 8

COMPONENTS

- 17** Back Board 2 x2

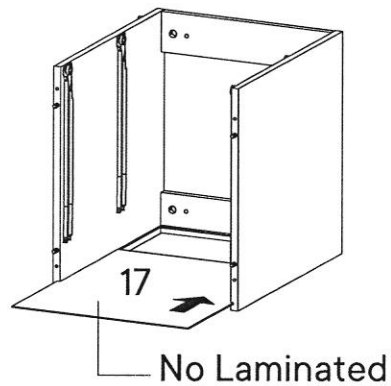
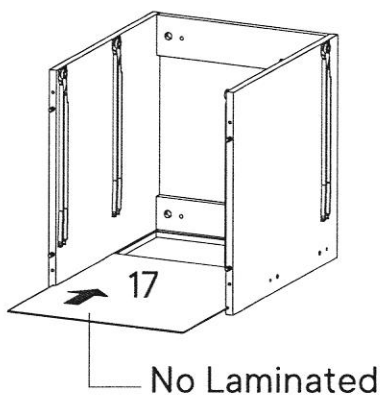

Step 9

HARDWARE

- I** Screw M 7 x 50 mm x8
- J** Allen Key x1

COMPONENTS

- 2** Bottom Board x2

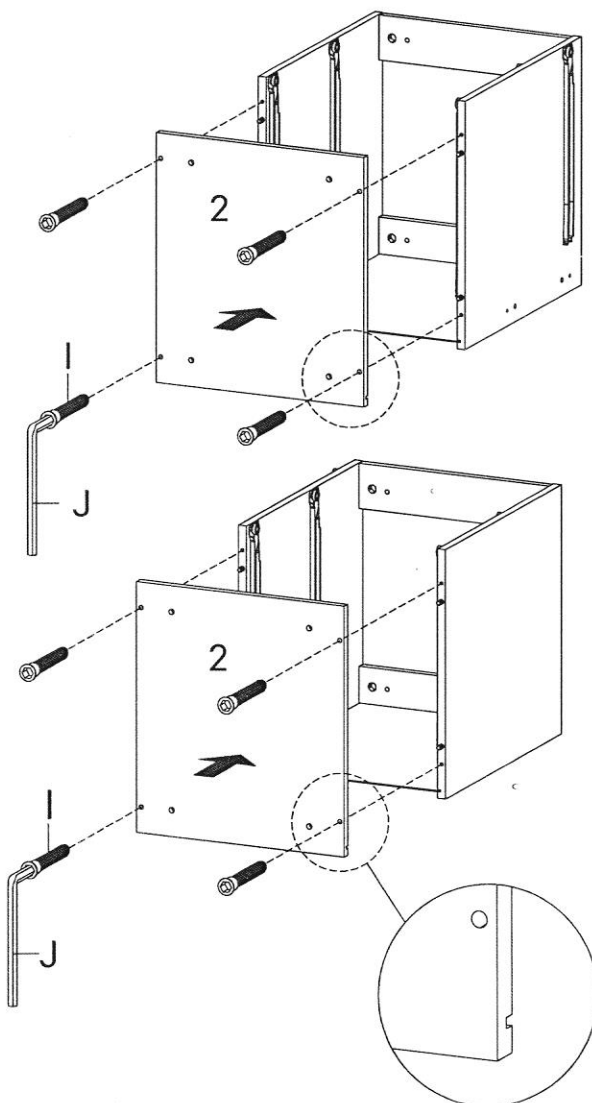
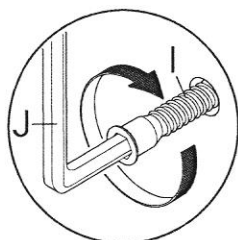

Step 10

COMPONENTS

LT34A1 Leg x8

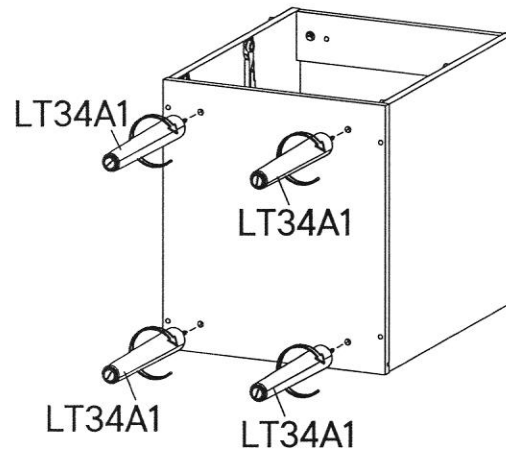
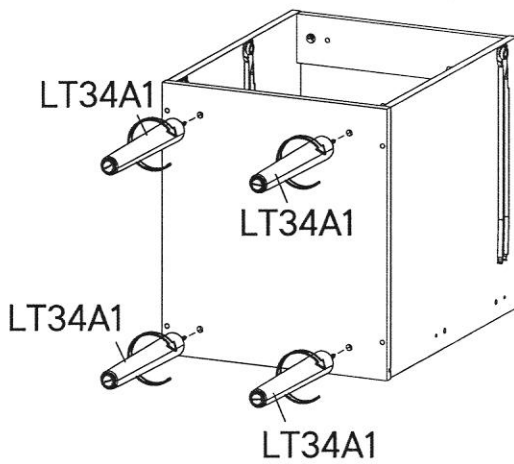
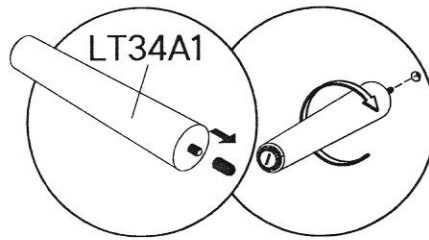

Step 11

HARDWARE

A Cam Bolt $\varnothing 6 \times 35$ mm x4

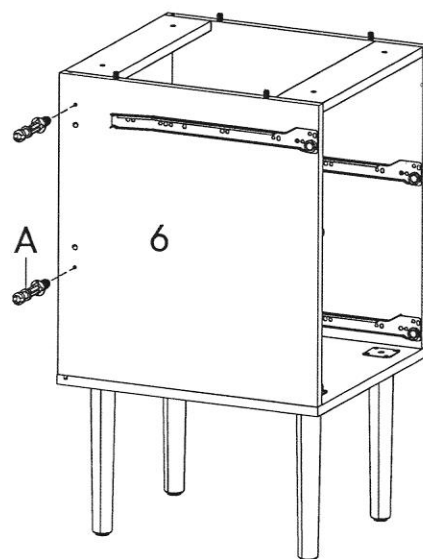
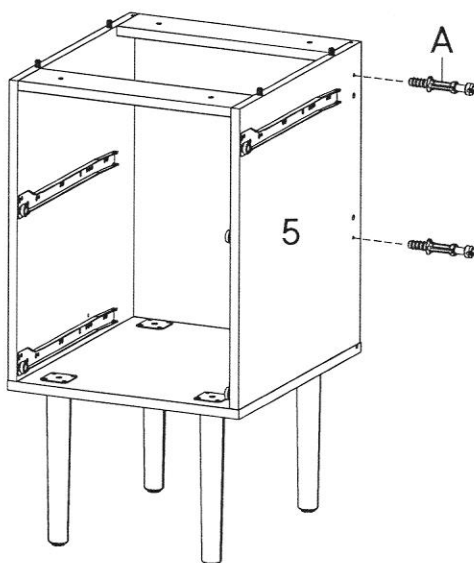
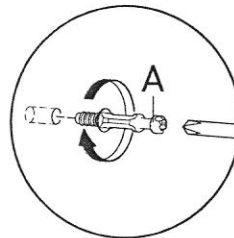

Step 12

HARDWARE

- A** Cam Bolt $\varnothing 6 \times 35$ mm x2
- E** Wood Dowel $\varnothing 8 \times 30$ mm x6

COMPONENTS

- 1** Top Board x1
- 7** Back Board 1 x1

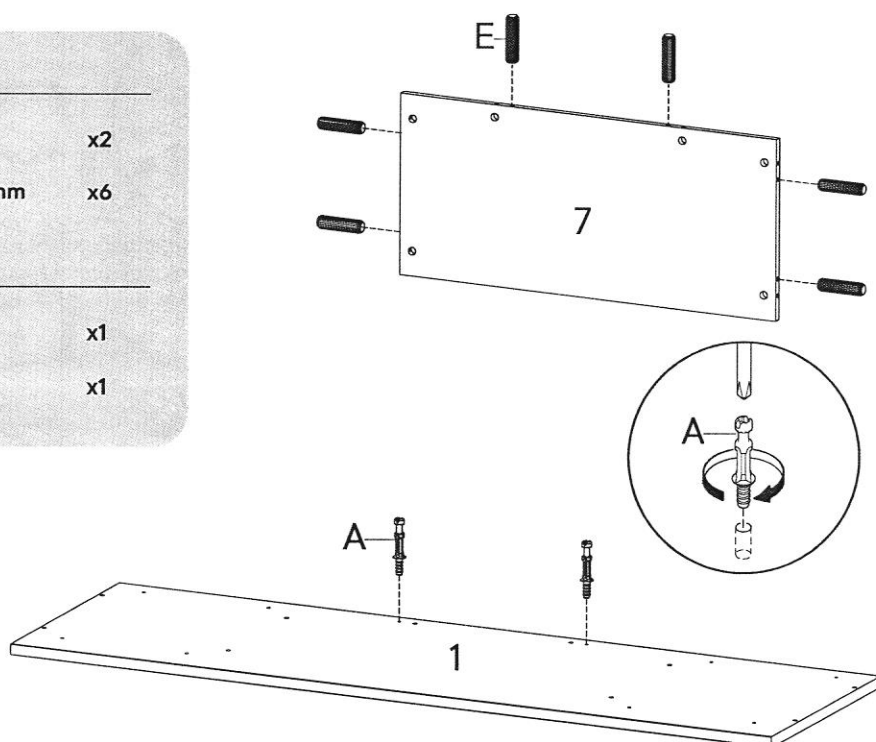

Step 13

HARDWARE

- B** Cam Lock $\varnothing 15$ mm x4
- O** Screw Cap $\varnothing 15$ mm x4

COMPONENTS

- 7** Back Board 1 x1

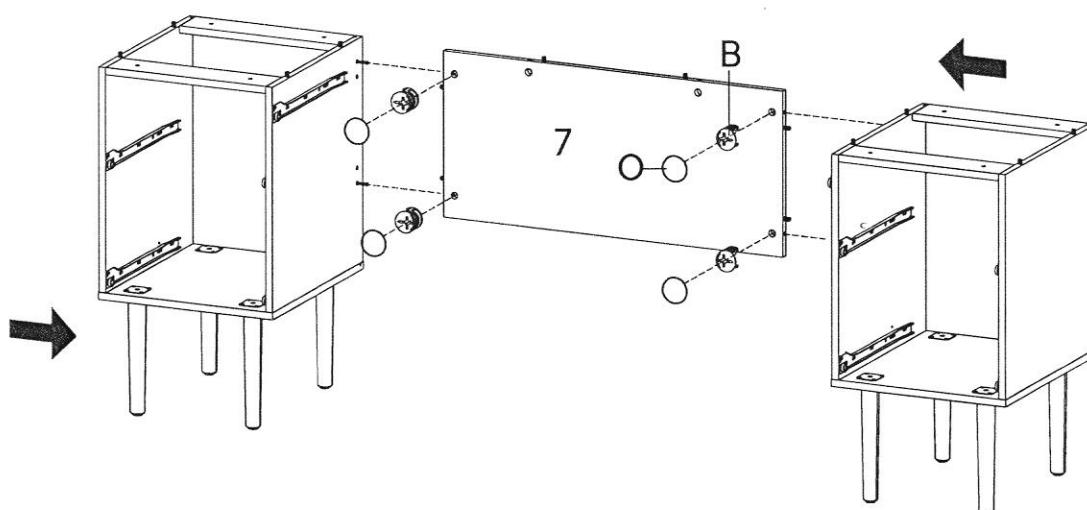
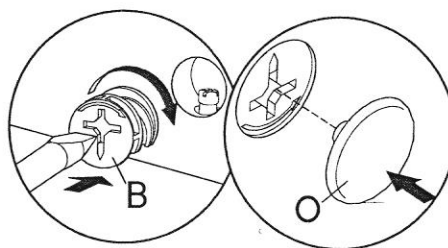

Step 14

HARDWARE

- B** Cam Lock Ø15 mm x2
- J** Allen Key x1
- M** Screw M 6.4 x 25 mm x8
- O** Screw Cap Ø15 mm x2

COMPONENTS

- 1** Top Board x1

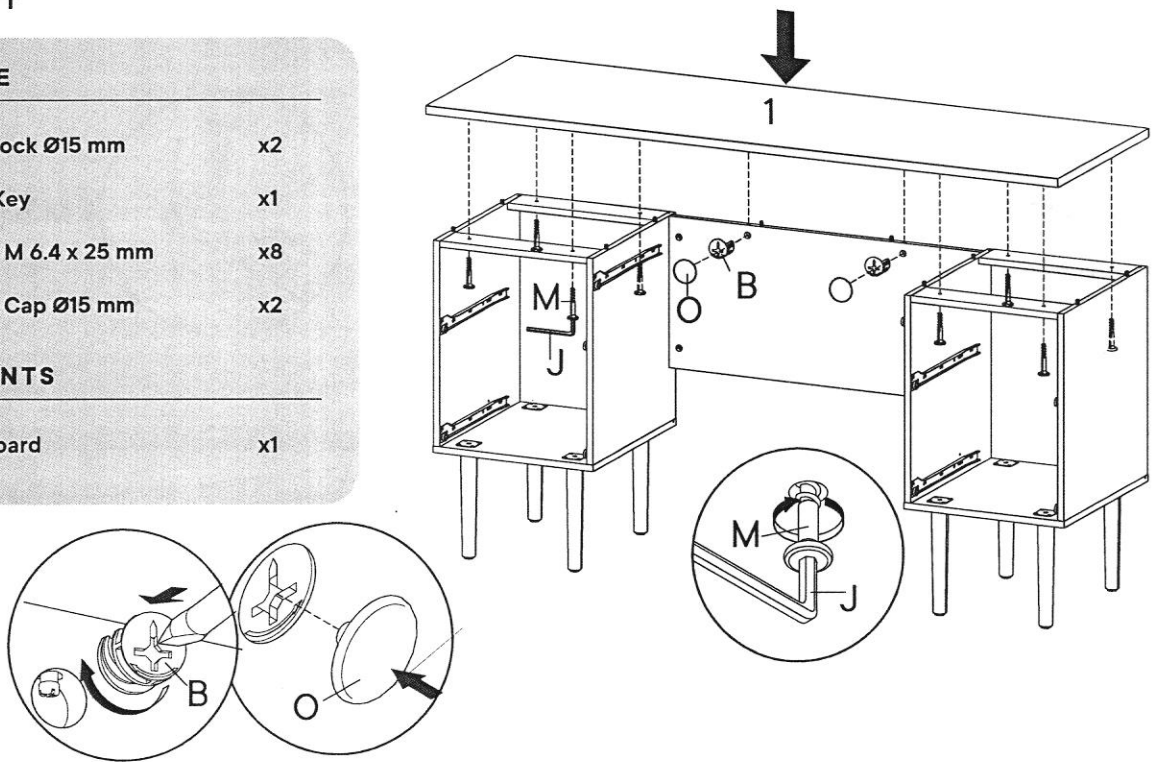

Step 15

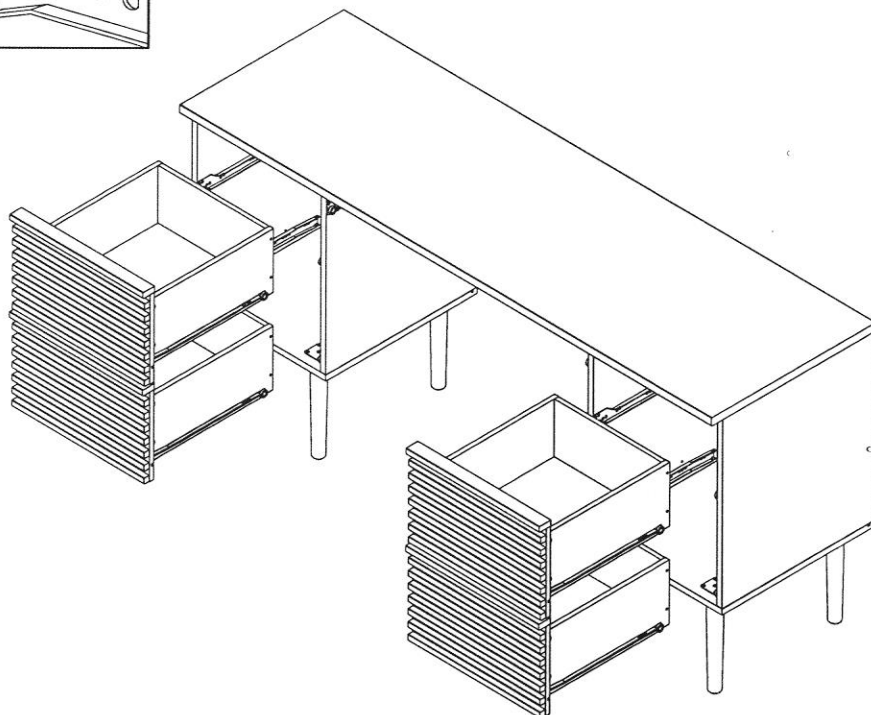
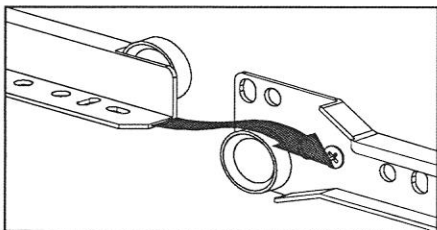

Step 16

HARDWARE

L Screw M 3.5 x 13 mm x6

RM35A Drawer Runner x1

COMPONENTS

13 Keyboard Base Drawer x1

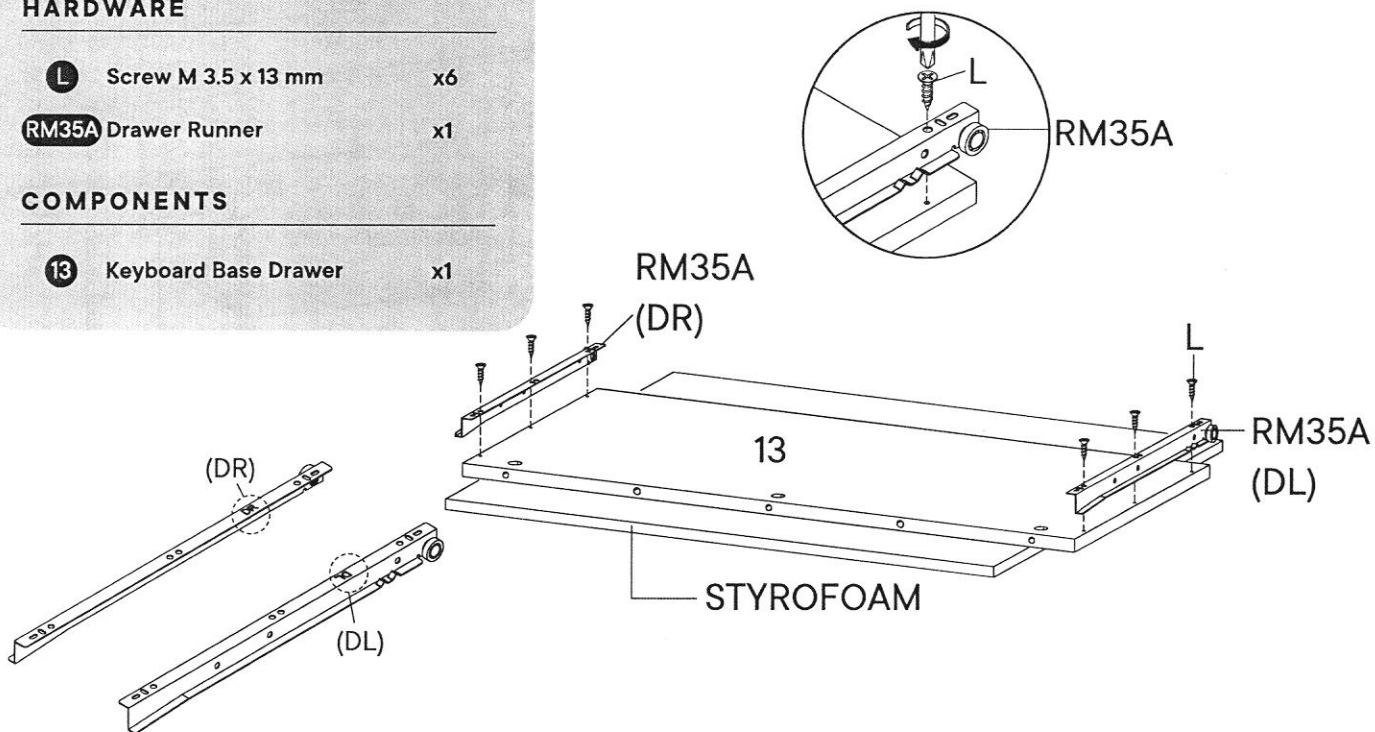

Step 17

HARDWARE

A Cam Bolt $\varnothing 6 \times 35$ mm x3

B Cam Lock $\varnothing 15$ mm x3

E Wood Dowel $\varnothing 8 \times 30$ mm x2

COMPONENTS

13 Keyboard Base Drawer x1

14 Front Skirt x1

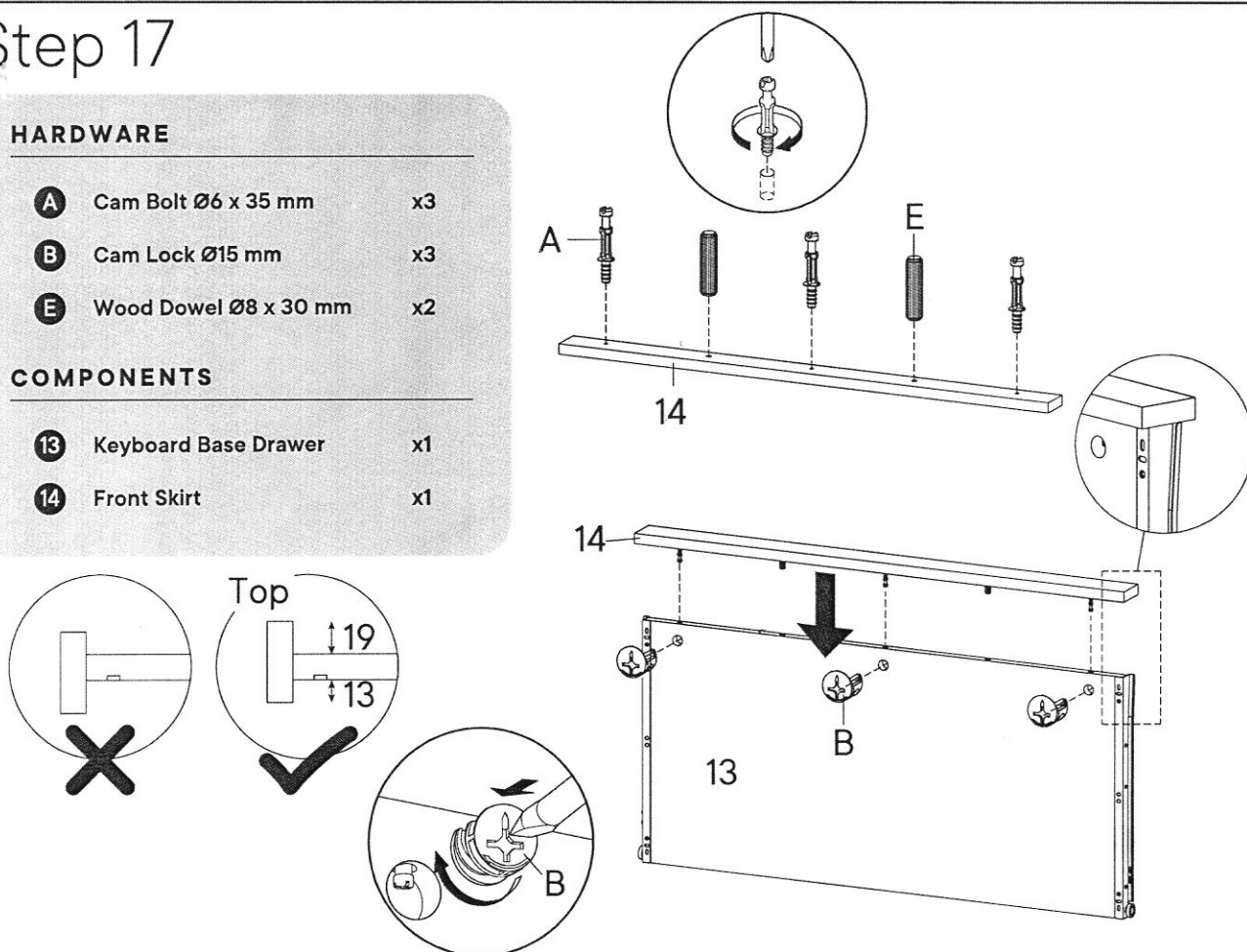

Step 18

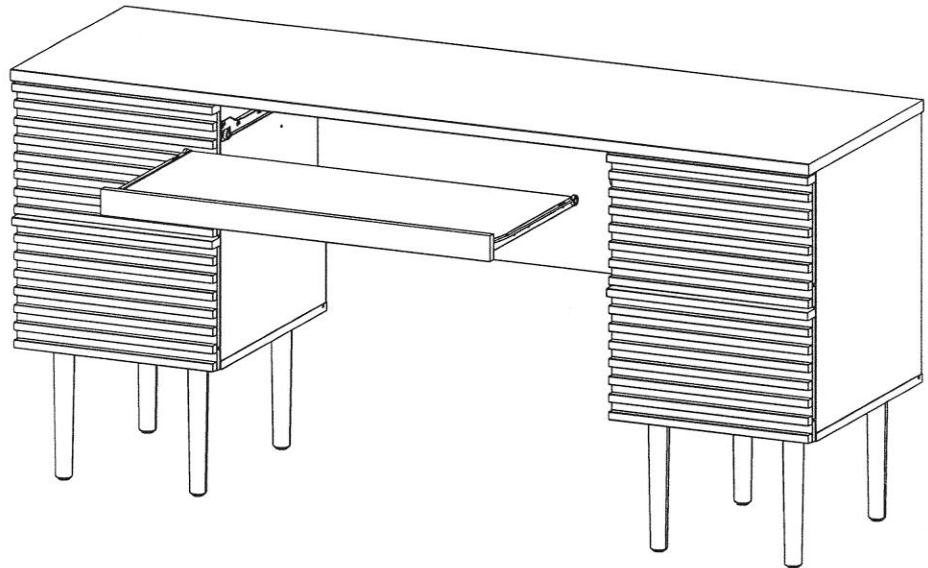
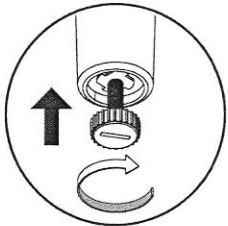
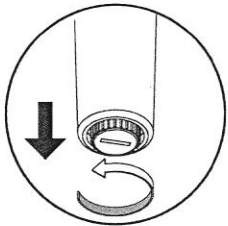
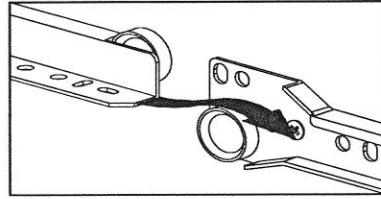

Step 19

HARDWARE

- G** Screw M 3.5 x 15.5 mm x8
- P** Wedge x8

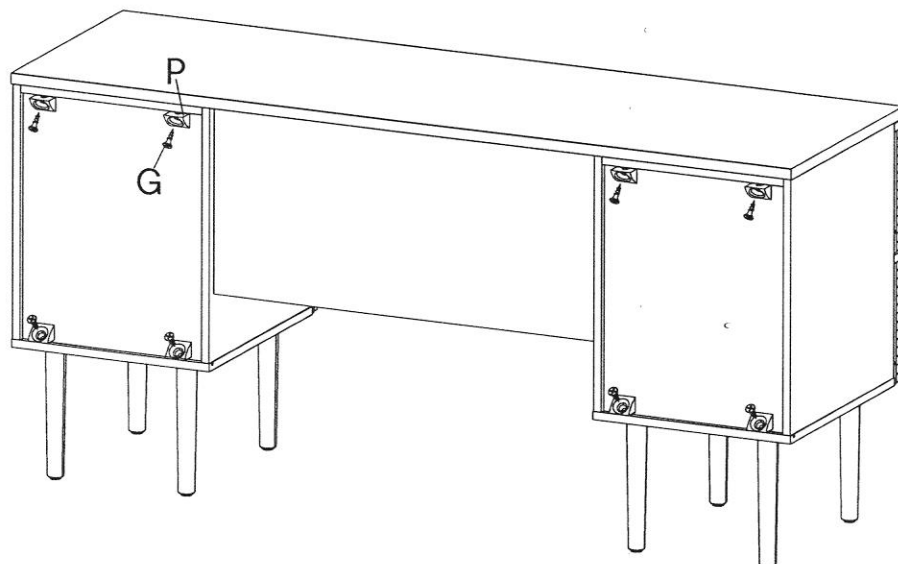
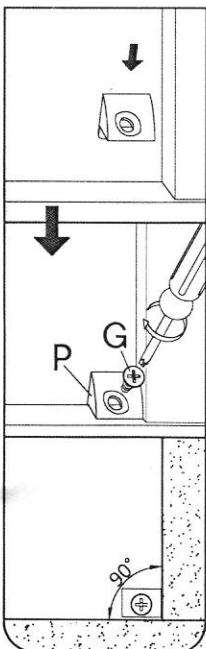

Great job!

Desk assembly is complete.

♥ CARING FOR YOUR ITEM

Indoor use only.

Not contract grade.

Clean using a non-abrasive cloth and a mild cleaner.

Never use harsh chemicals, as they could damage the finish or integrity of the item.

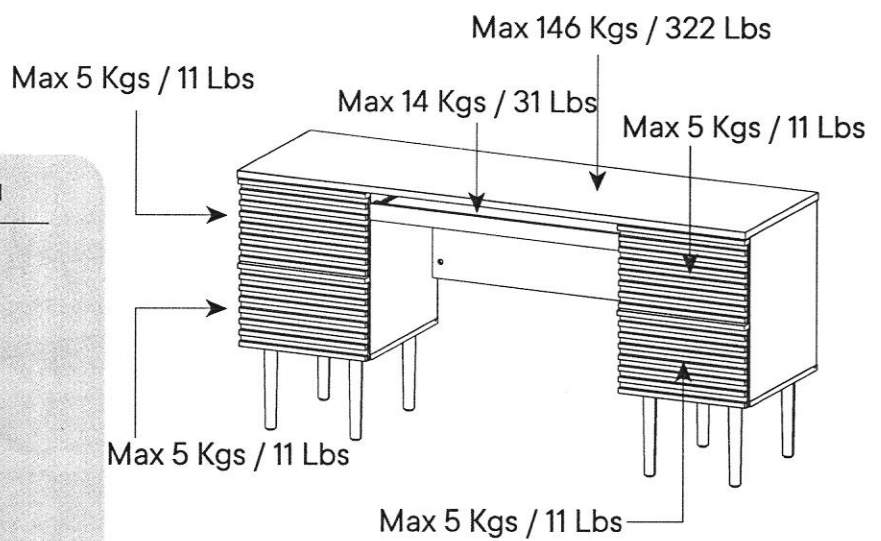

CONNECT WITH US!   

Tag us @modway_furniture and #modway for a chance to be featured.