

# ASSEMBLY INSTRUCTIONS

# EEI-5703

V0.08.04.21

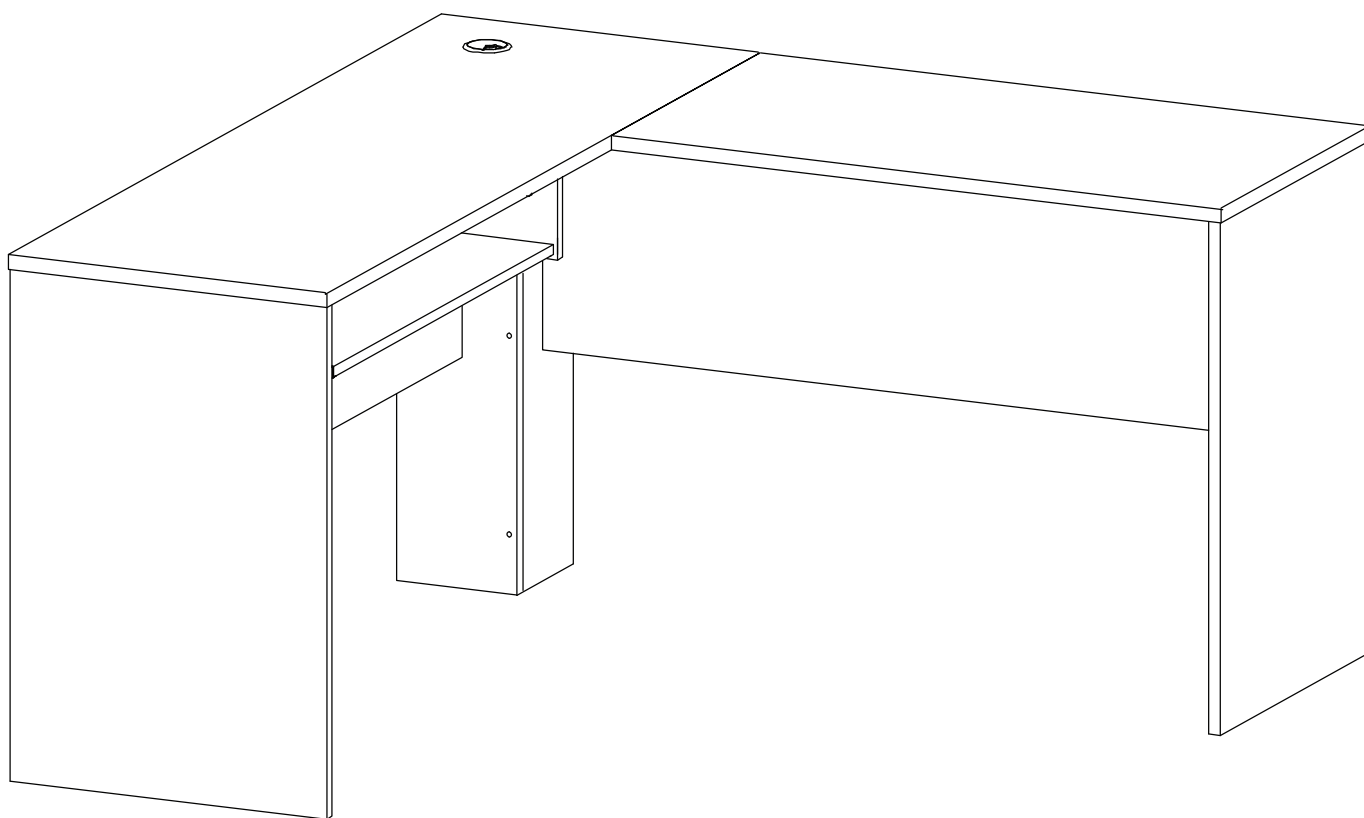

**Questions? Contact us!**

609.256.9000 • [cs@modway.com](mailto:cs@modway.com)  
[www.modway.com](http://www.modway.com)

\*modway



Read through all of the instructions before starting



Care instructions are listed in the last step of this manual

**Only use hand tools to assemble this item.** Do not use power tools. Do not tighten bolts or screws completely until all hardware is lined up and inserted into the holes.



Approx. 90 minutes assembly time



Make sure you have all parts and components before discarding any packing materials

Do not over-tighten screws and bolts to avoid stripping the hardware or cracking the item.

Assemble your item on a flat, carpeted area, with plenty of space to work. This will prevent damage and scratches to your floors or the item while you're assembling the product.



2 people recommended for assembly

Keep all components and packaging out of reach of children or animals to avoid risk of choking or suffocation.

## Furniture components:

1	Top Board 1	x1
2	Top Board 2	x1
3	Side Board Left	x1
4	Side Board Right	x1
5	Center Board 1	x1
6	Center Board 2	x1
7	Center Board 3	x1
8	Keyboard Drawer Base	x1
9	Back Board 1	x1
10	Back Board 2	x1

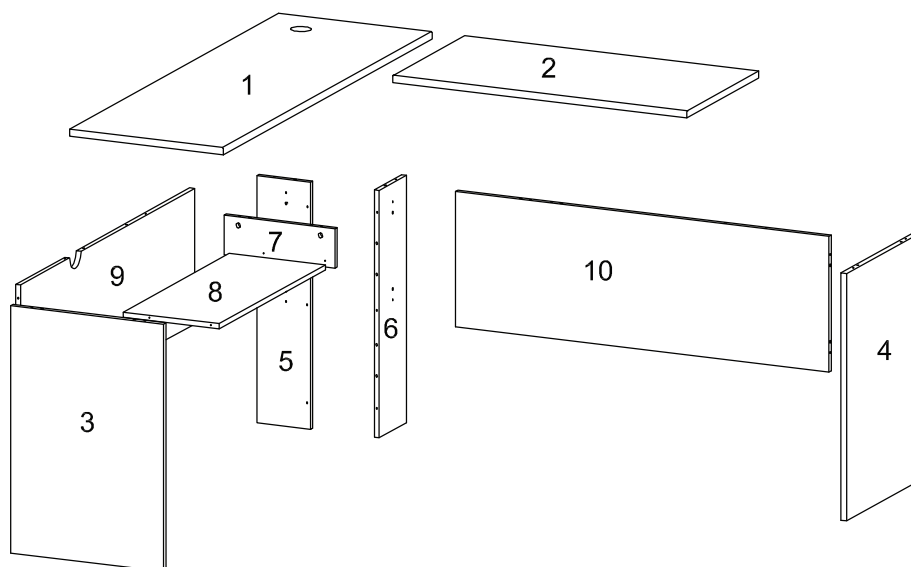

## Provided hardware:

A		Cam Bolt $\varnothing 6 \times 35$ mm	x19
B		Cam Lock $\varnothing 15$ mm	x19
C		Wood Dowel $\varnothing 8 \times 30$ mm	x25
D		Screw M 6 x 10.5 mm	x8
E		Screw M 4.5 x 12.5 mm	x12
F		Grommet Cover	x1
G		Screw M 7 x 50 mm	x8
H		Allen Key	x1
I		Mending Plates	x2

## What you need:

J		Screw Cap $\varnothing 15$ mm	x15
K		Screw Cap $\varnothing 15$ mm	x4
L		Shoe Plate	x6
RB25A		Keyboard Drawer Runner	x1

Phillips Head Screwdriver

**Wait!**

Missing parts or hardware? Need assistance?  
Contact us before returning your item. We're here to help!  
609.256.9000 • cs@modway.com

# Step 1

## HARDWARE

- C** Wood Dowel Ø8x30 mm x6
- L** Shoe Plate x2

## COMPONENTS

- 5** Center Board 1 x1
- 6** Center Board 2 x1

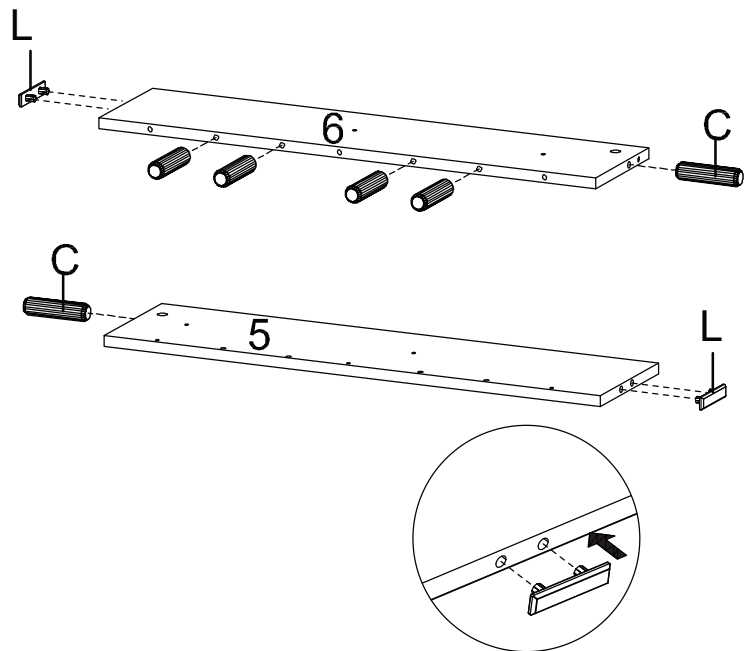

# Step 2

## HARDWARE

- G** Screw M 7 x 50 mm x3
- H** Allen Key x1

## COMPONENTS

- 5** Center Board 1 x1
- 6** Center Board 2 x1

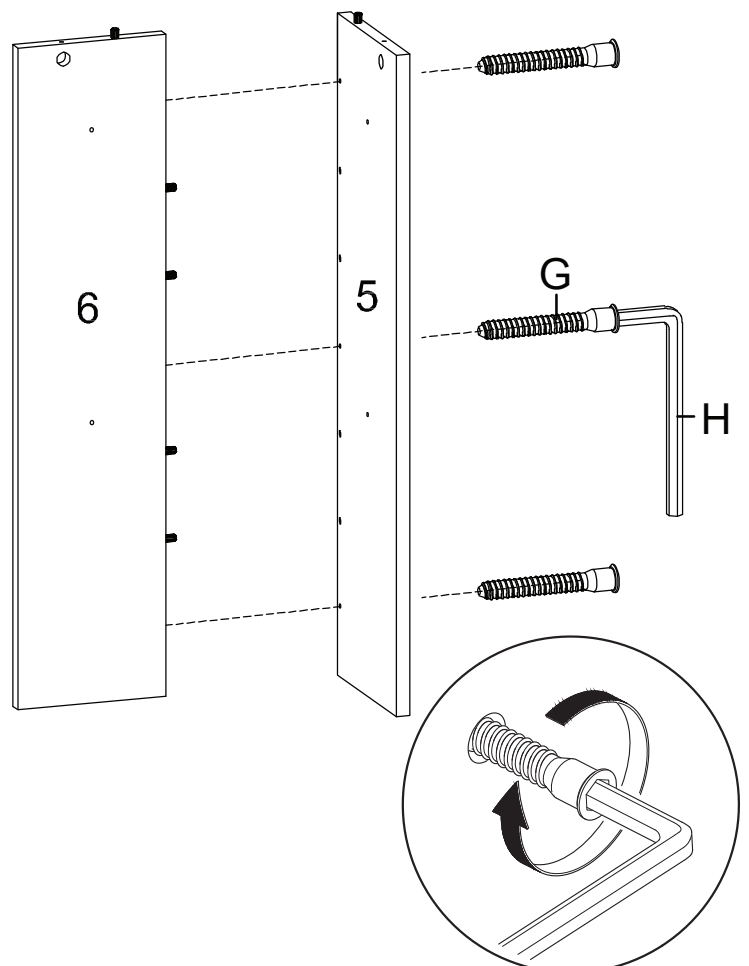

## Step 3

### HARDWARE

- A** Cam Bolt  $\varnothing 6 \times 35$  mm x2
- C** Wood Dowel  $\varnothing 8 \times 30$  mm x10
- D** Screw M 6 x 10.5 mm x4
- RB25A** Keyboard Drawer Runner x1
- L** Shoe Plate x2

### COMPONENTS

- 3** Side Board Left x1
- 7** Center Board 3 x1
- 9** Back Board 1 x1

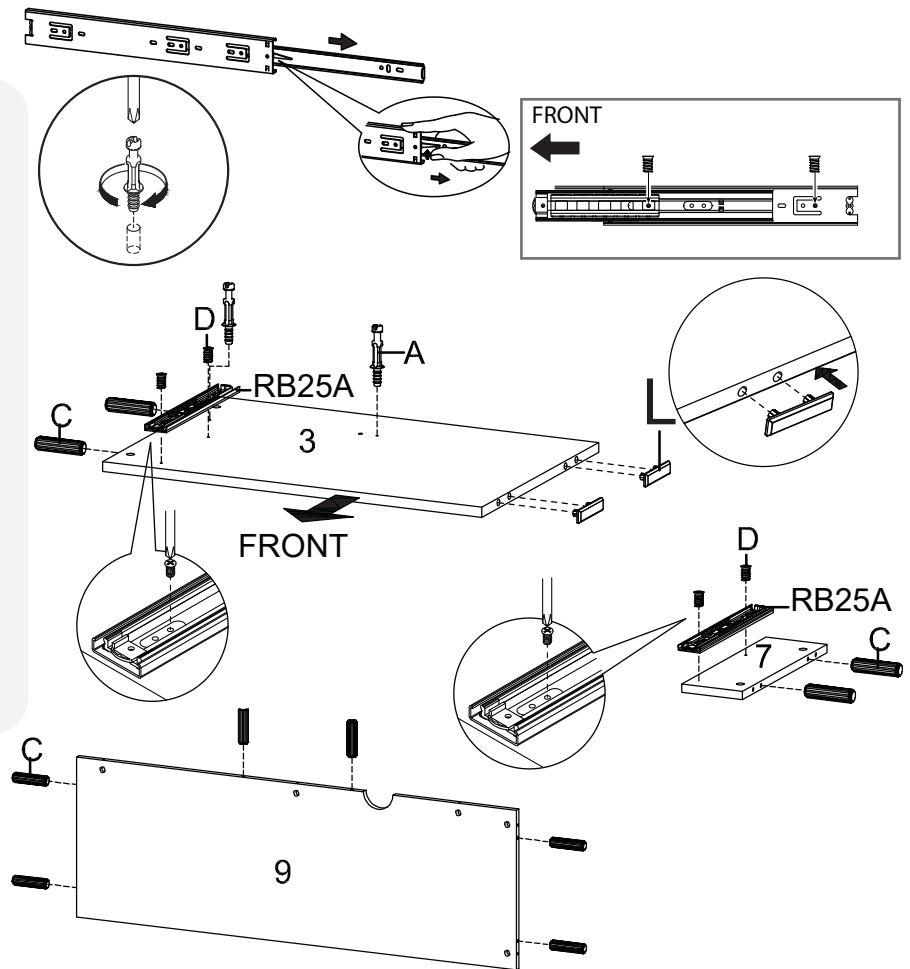

## Step 4

### HARDWARE

- B** Cam Lock  $\varnothing 15$  mm x2
- J** Screw Cap  $\varnothing 15$  mm x2

### COMPONENTS

- 3** Side Board Left x1
- 9** Back Board 1 x1

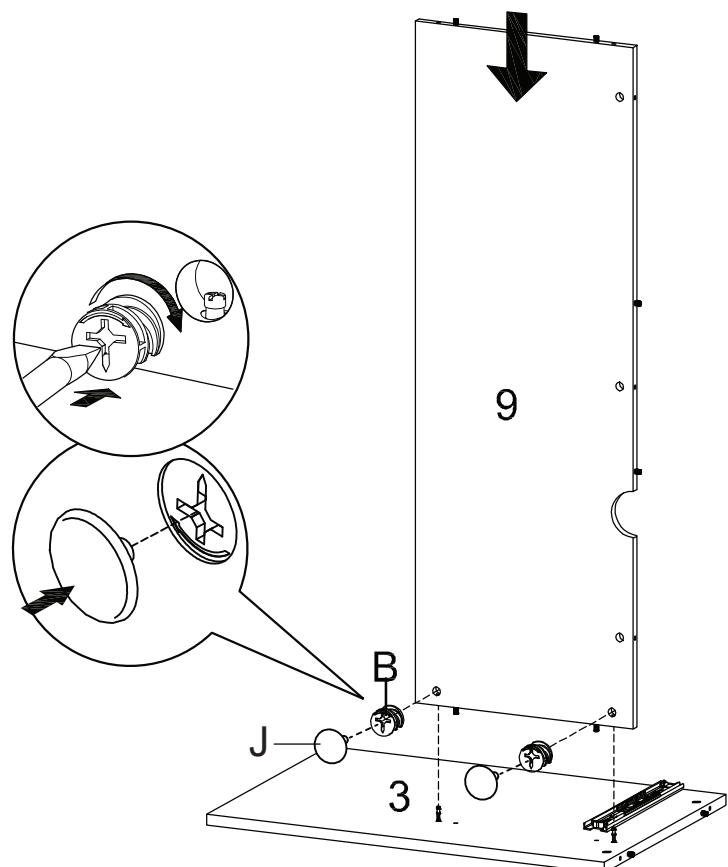

## Step 5

### HARDWARE

- G** Screw M 7 x 50 mm x2
- H** Allen Key x1

### COMPONENTS

- 3** Side Board Left x1
- 9** Back Board 1 x1

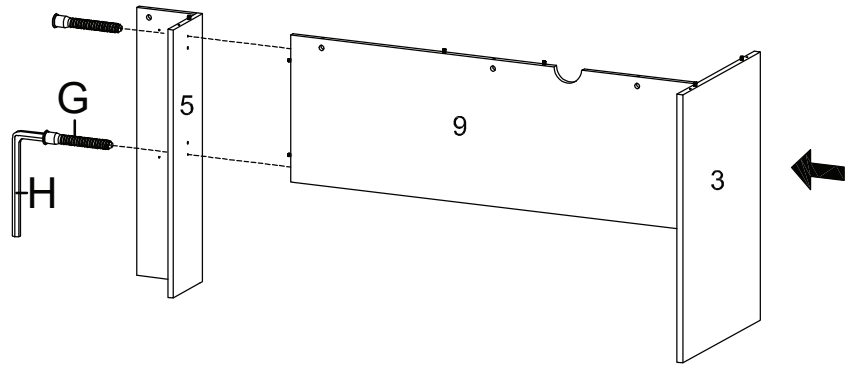
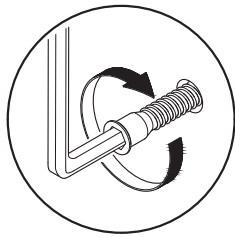

## Step 6

### HARDWARE

- A** Cam Bolt  $\varnothing 6 \times 35$  mm x2
- C** Wood Dowel  $\varnothing 8 \times 30$  mm x9
- L** Shoe Plate x2

### COMPONENTS

- 4** Side Board Right x1
- 10** Back Board 2 x1

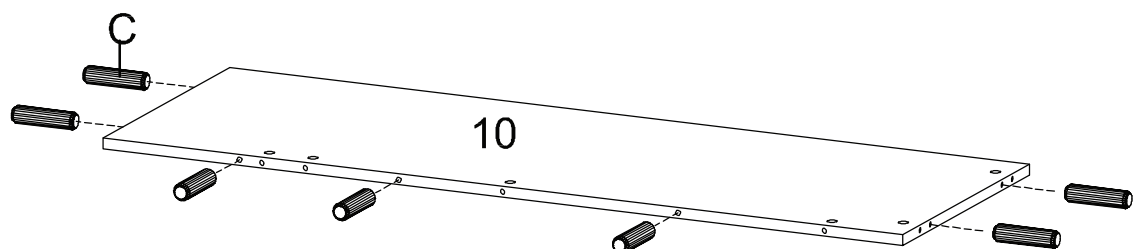
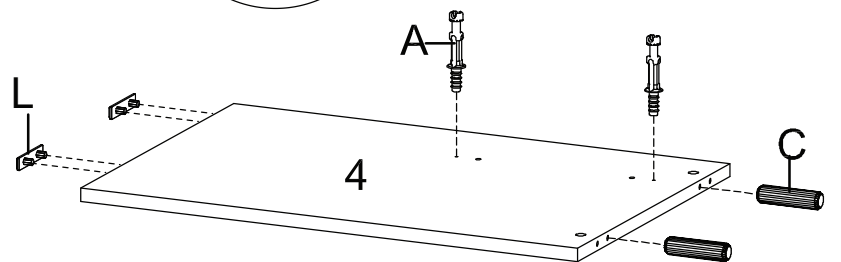
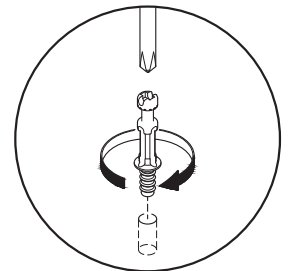
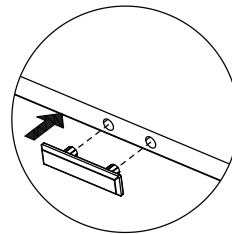

## Step 7

### HARDWARE

- B** Cam Lock Ø15 mm x2
- J** Screw Cap Ø15 mm x2

### COMPONENTS

- 4** Side Board Right x1
- 10** Back Board 2 x1

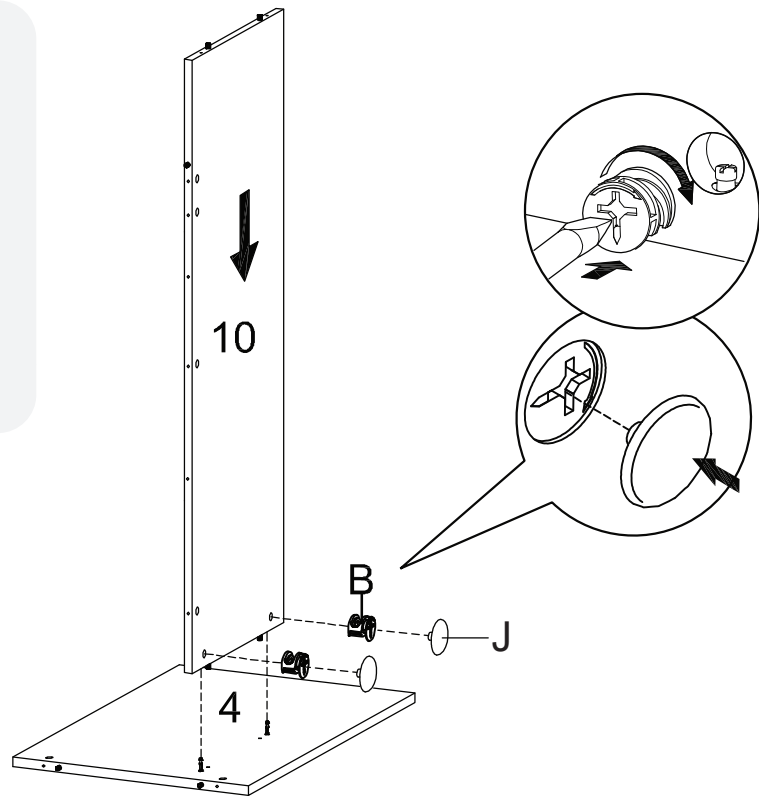

## Step 8

### HARDWARE

- G** Screw M 7 x 50 mm x2
- H** Allen Key x1

### COMPONENTS

- 4** Side Board Right x1
- 10** Back Board 2 x1

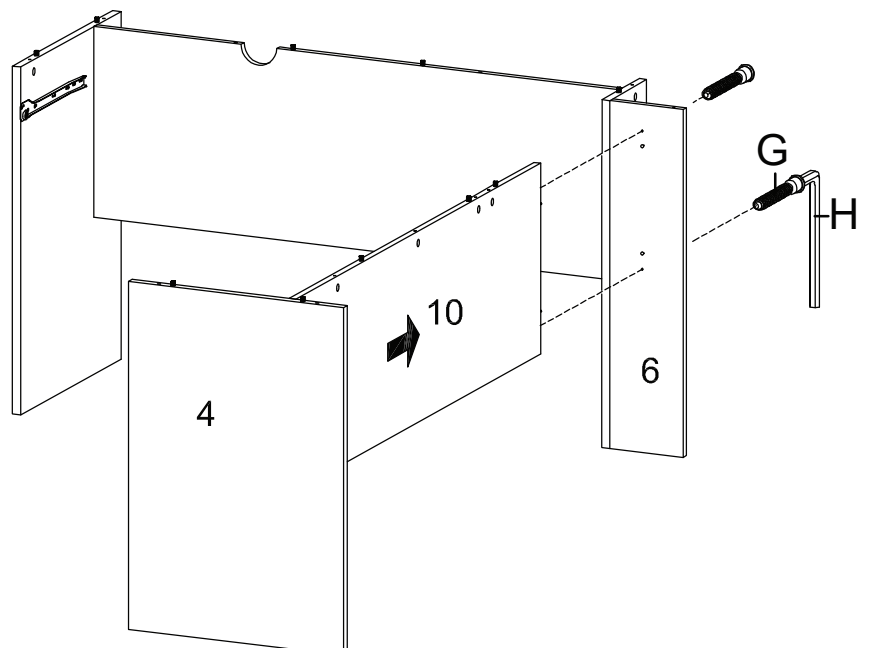

# Step 9

## HARDWARE

- A** Cam Bolt  $\varnothing 6 \times 35$  mm x15
- I** Mending Plates x2
- E** Screw M 4.5 x 12.5 mm x6

## COMPONENTS

- 1** Top Board 1 x1
- 2** Top Board 2 x1

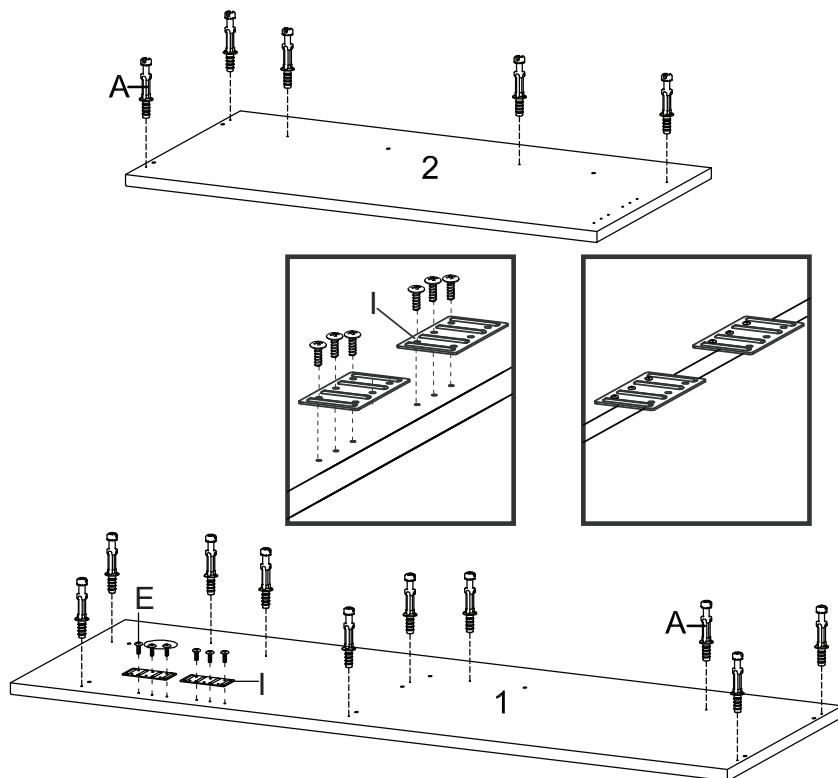

# Step 10

## HARDWARE

- B** Cam Lock  $\varnothing 15$  mm x8
- J** Screw Cap  $\varnothing 15$  mm x6
- K** Screw Cap  $\varnothing 15$  mm x2

## COMPONENTS

- 1** Top Board 1 x1

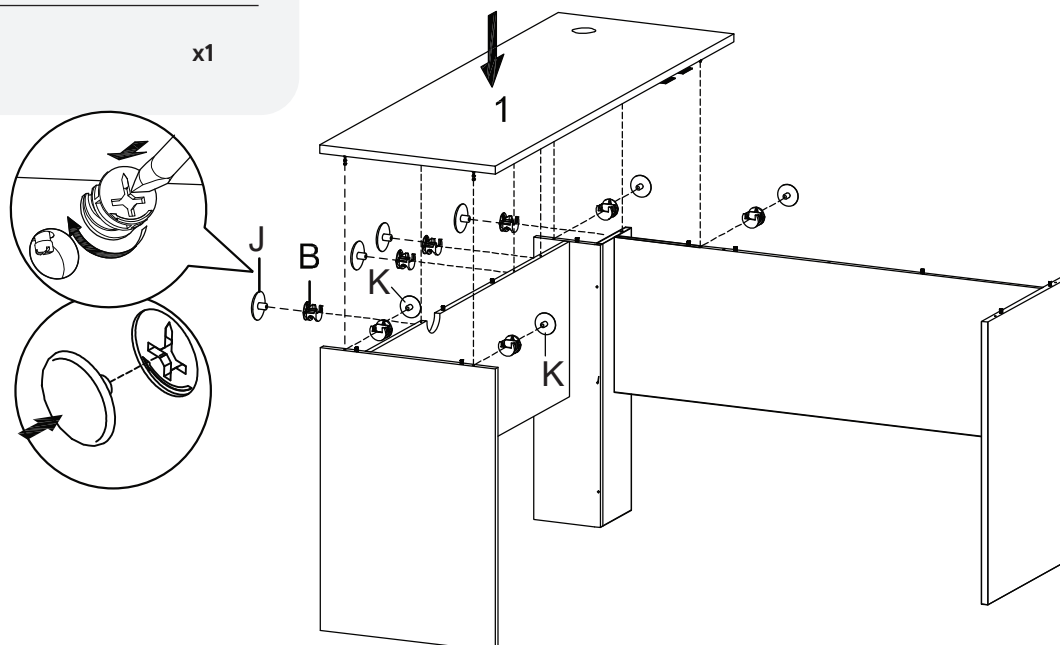

# Step 11

## HARDWARE

- B** Cam Lock Ø15 mm x5
- J** Screw Cap Ø15 mm x3
- K** Screw Cap Ø15 mm x2

## COMPONENTS

- 2** Top Board 2 x1

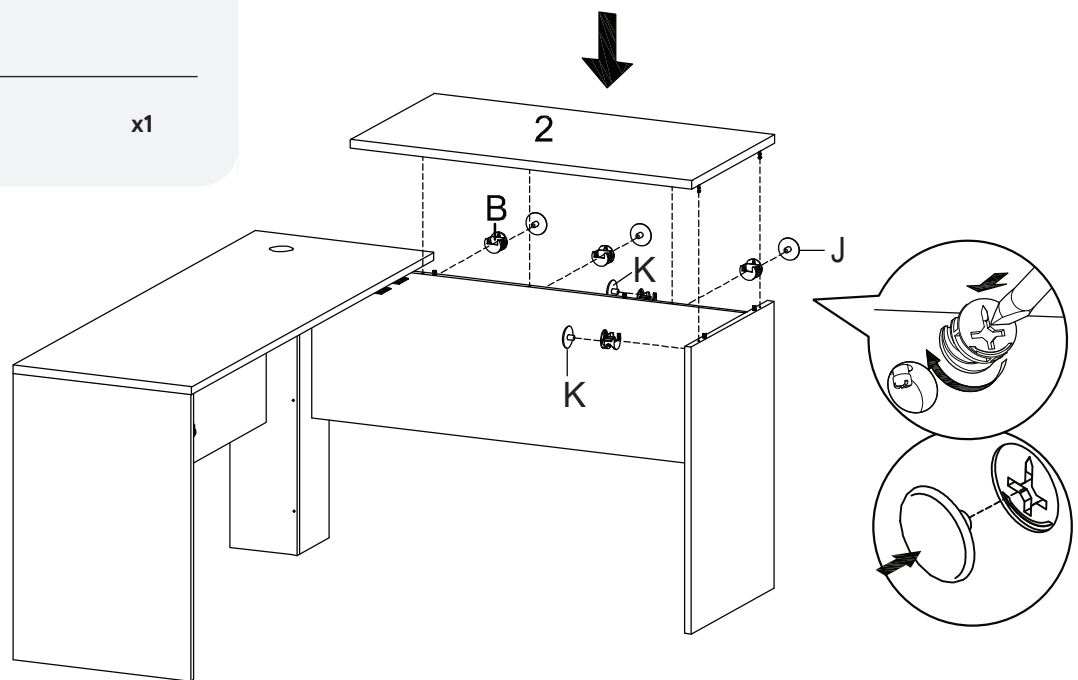

# Step 12

## HARDWARE

- E** Screw M 4.5 x 12.5 mm x6

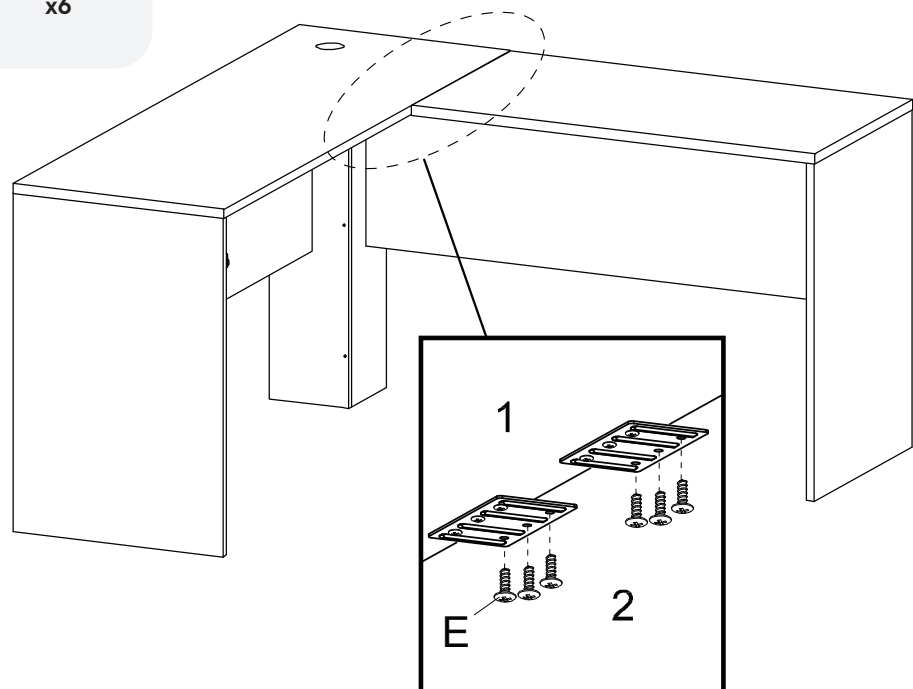

## Step 13

### HARDWARE

- B** Cam Lock Ø15 mm x2
- J** Screw Cap Ø15 mm x2

### COMPONENTS

- 7** Center Board 3 x1

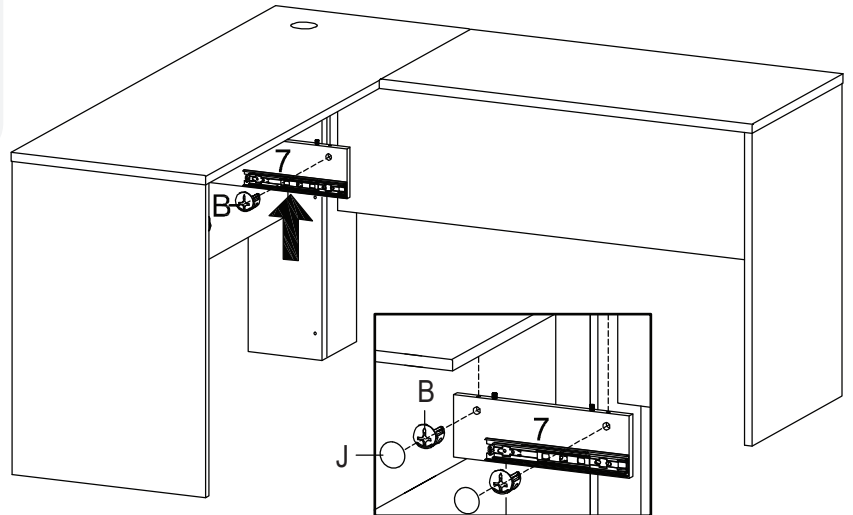

## Step 14

### HARDWARE

- G** Screw M 7 x 50 mm x1
- H** Allen Key x1

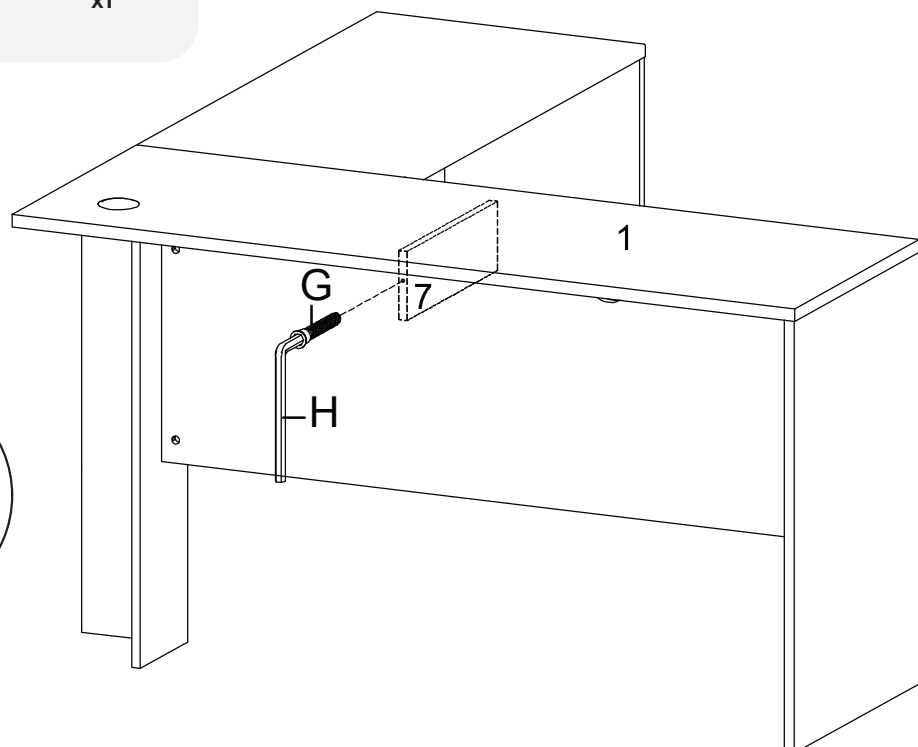
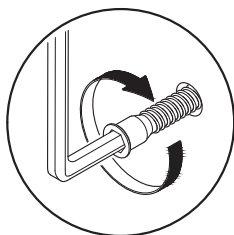

# Step 15

## HARDWARE

- D** Screw M 6 x 10.5 mm x4
- RB25A** Keyboard Drawer Runner x1

## COMPONENTS

- 8** Keyboard Drawer Base x1

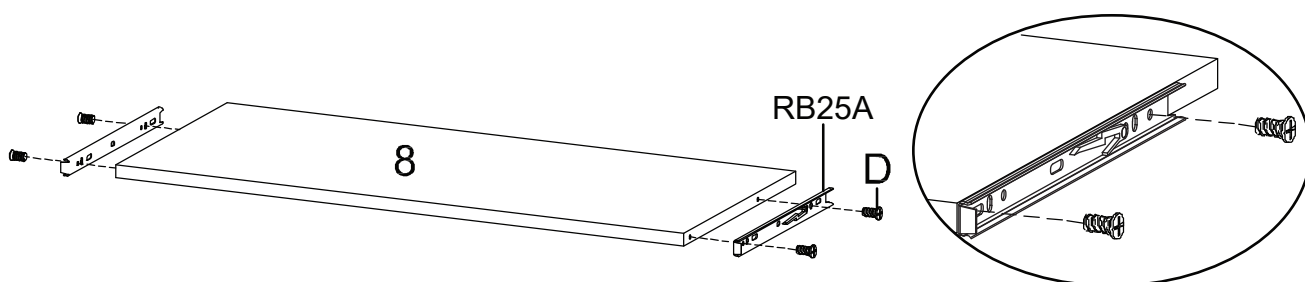
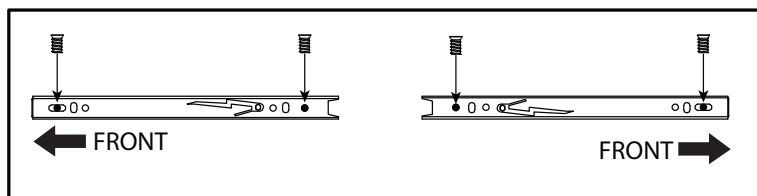

# Step 16

## HARDWARE

- F** Grommet Cover x1

## COMPONENTS

- 8** Keyboard Drawer Base x1

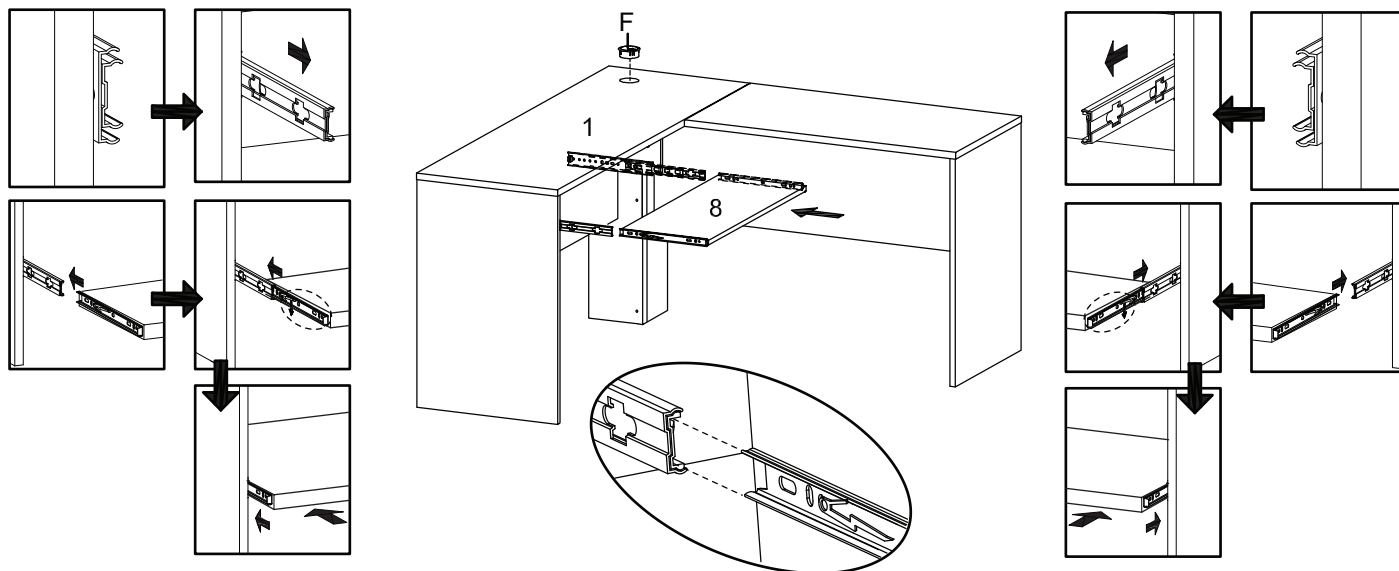

# Great job!

Desk assembly is complete

## ♥ CARING FOR YOUR ITEM

Indoor use only.

Not contract grade.

Clean using a non-abrasive cloth and a mild cleaner.

Never use harsh chemicals, as they could damage the finish or integrity of the item.

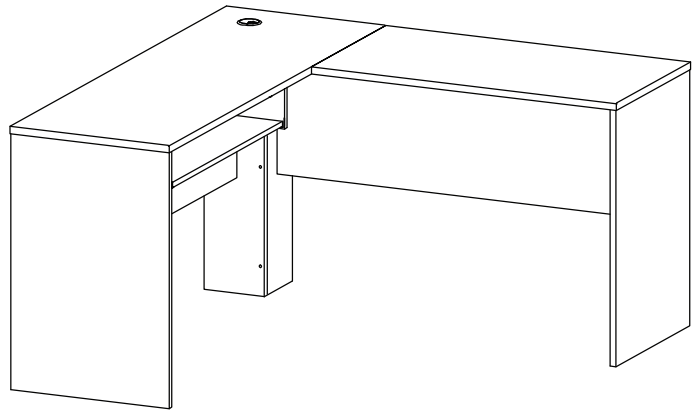

CONNECT WITH US!   

Tag us [@modway\\_furniture](#) and [#modway](#) for a chance to be featured.

## ASSEMBLY INSTRUCTIONS

# EEI-5706

V0.08.04.21

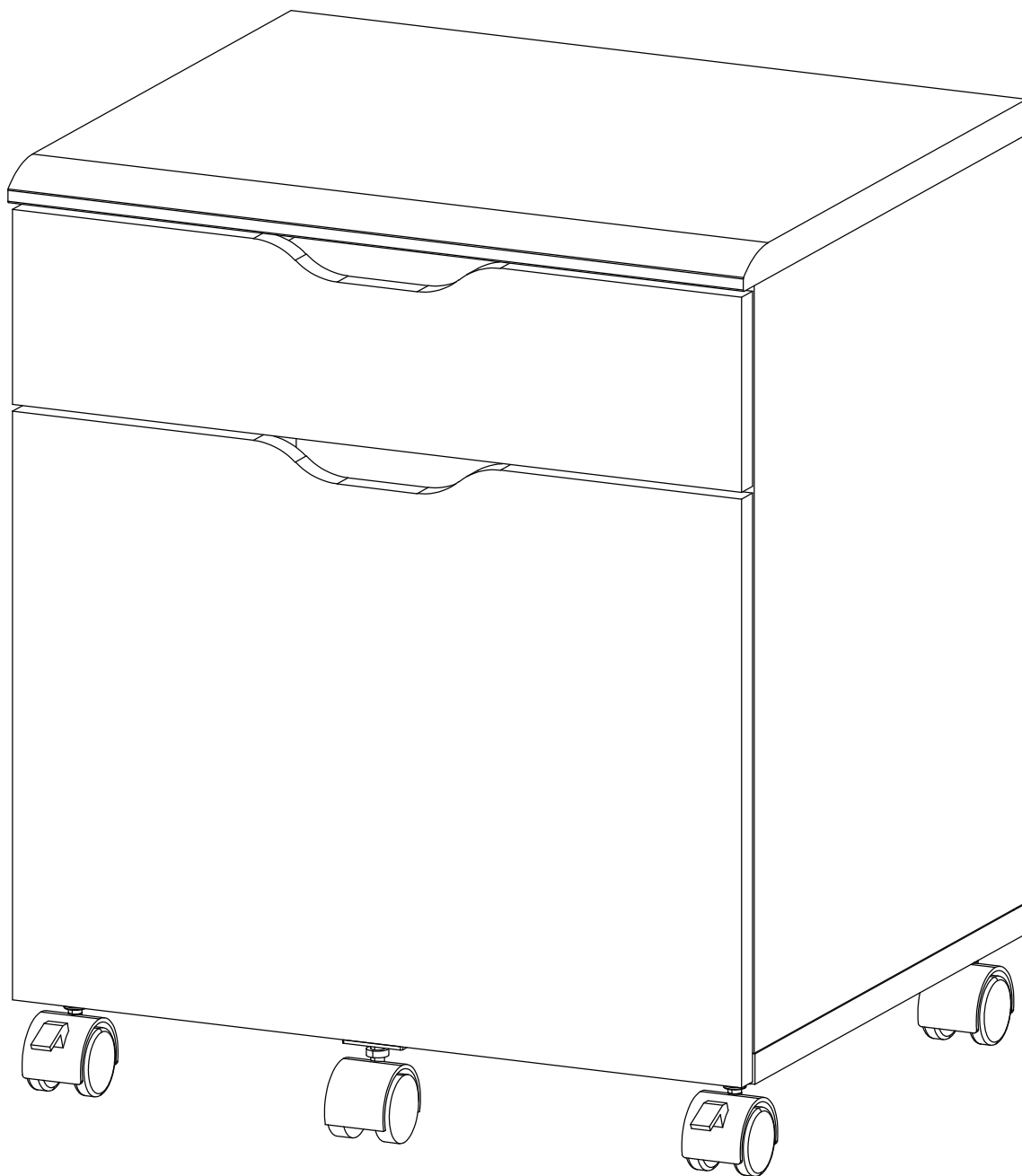

**Questions? Contact us!**

609.256.9000 • [cs@modway.com](mailto:cs@modway.com)  
[www.modway.com](http://www.modway.com)

**\*modway**

# Let's get started!

\*modway



Read through all of the instructions before starting



Care instructions are listed in the last step of this manual



Approx. 90 minutes assembly time



Make sure you have all parts and components before discarding any packing materials



2 people recommended for assembly

**Only use hand tools to assemble this item.** Do not use power tools. Do not tighten bolts or screws completely until all hardware is lined up and inserted into the holes.

Do not over-tighten screws and bolts to avoid stripping the hardware or cracking the item.

Assemble your item on a flat, carpeted area, with plenty of space to work. This will prevent damage and scratches to your floors or the item while you're assembling the product.

Keep all components and packaging out of reach of children or animals to avoid risk of choking or suffocation.

## Furniture components:

1	Top Board	x1	11	Side Drawer Left Big	x1
2	Bottom Board	x1	12	Side Drawer Right Big	x1
3	Side Board Left	x1	13	Back Drawer Big	x1
4	Side Board Right	x1	14	Back Board	x2
5	Front Drawer Small	x1			
6	Side Drawer Left Small	x1			
7	Side Drawer Right Small	x1			
8	Back Drawer Small	x1			
9	Bottom Drawer	x2			
10	Front Drawer Big	x1			

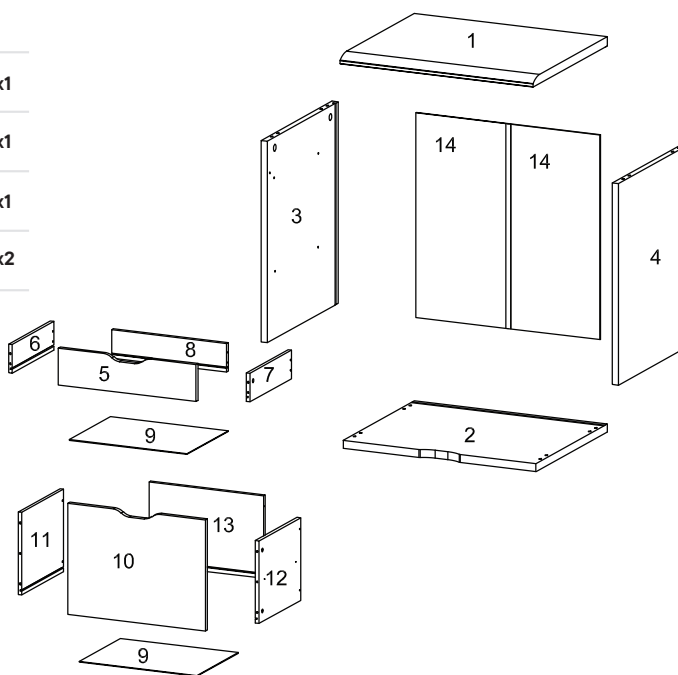

## Provided hardware:

A		Cam Bolt Ø6 x 35 mm	x10	J		Screw M 3.5 x 13 mm	x8	RM30A		Drawer Runner	x1
B		Cam Lock Ø15 mm	x4	K		Screw M 7 x 50 mm	x4	RB24A		Drawer Runner	x1
C		Cam Lock Ø12 mm	x6	L		Allen Key	x1				
D		Wood Dowel Ø8x30 mm	x8	M		File Hang Rail	x2				
E		Wood Dowel Ø6x30 mm	x4	N		Castor With Stopper	x2				
F		Gap Cover Strip	x1	O		Castor	x2				
G		Castor With Plate	x1	P		Screw M 3.5 x 15.5 mm	x14				
H		Screw M 6 x 10.5 mm	x14	Q		Wedge	x14				
I		Screw M 8 x 39 mm	x8	R		Screw M 4 x 16 mm	x16				

## What you need:

Phillips Head Screwdriver

Wait!

Missing parts or hardware? Need assistance?  
Contact us before returning your item. We're here to help!  
609.256.9000 • cs@modway.com

# Step 1

## HARDWARE

**A** Cam Bolt  $\varnothing 6 \times 35$  mm x4

## COMPONENTS

**1** Top Board x1

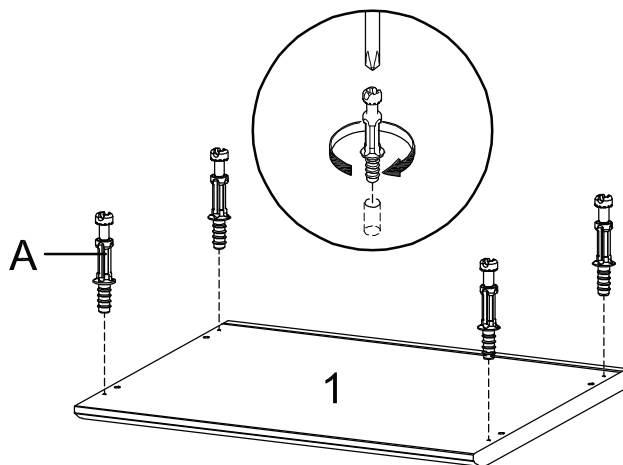

# Step 2

## HARDWARE

**D** Wood Dowel  $\varnothing 8 \times 30$  mm x8

**H** Screw M 6 x 10.5 mm x10

**RM30A** Drawer Runner x1

**RB24A** Drawer Runner x1

## COMPONENTS

**3** Side Board Left x1

**4** Side Board Right x1

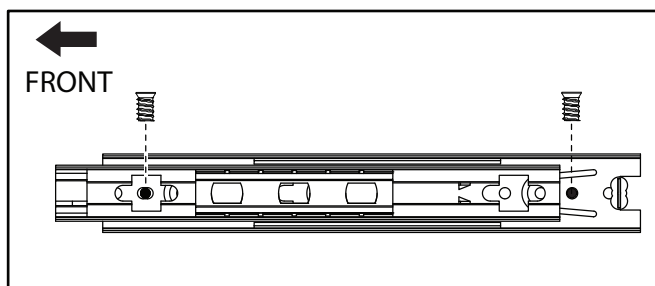
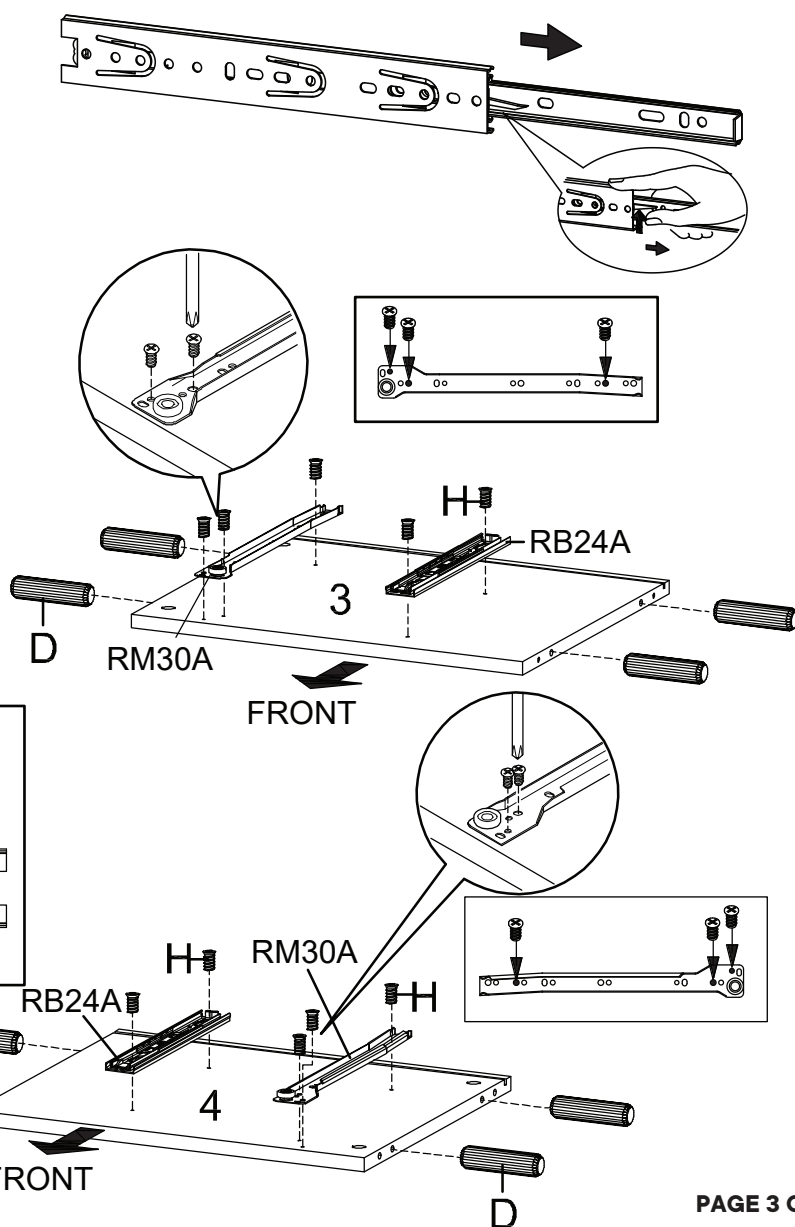

## Step 3

### HARDWARE

**B** Cam Lock Ø15 mm x4

### COMPONENTS

**1** Top Board x1

**3** Side Board Left x1

**4** Side Board Right x1

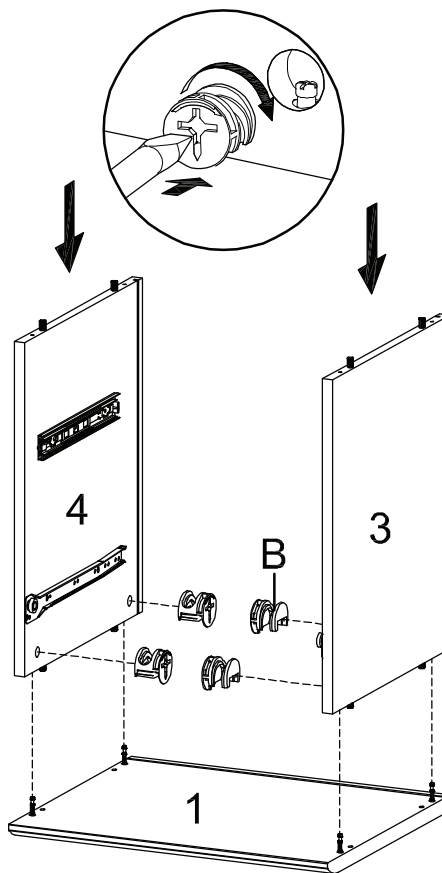

## Step 4

### HARDWARE

**F** Gap Cover Strip x1

**K** Screw M 7 x 50 mm x4

**L** Allen Key x1

### COMPONENTS

**2** Bottom Board x1

**14** Back Board x2

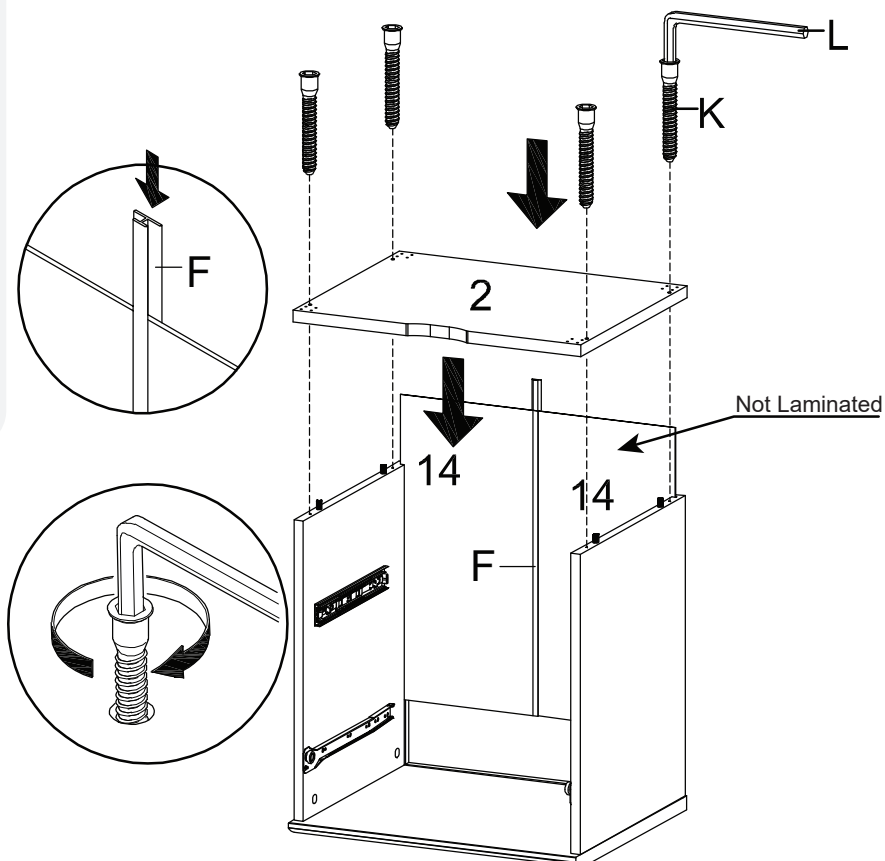

# Step 5

## HARDWARE

- N** Castor With Stopper x2
- O** Castor x2
- R** Screw M 4 x 16 mm x16

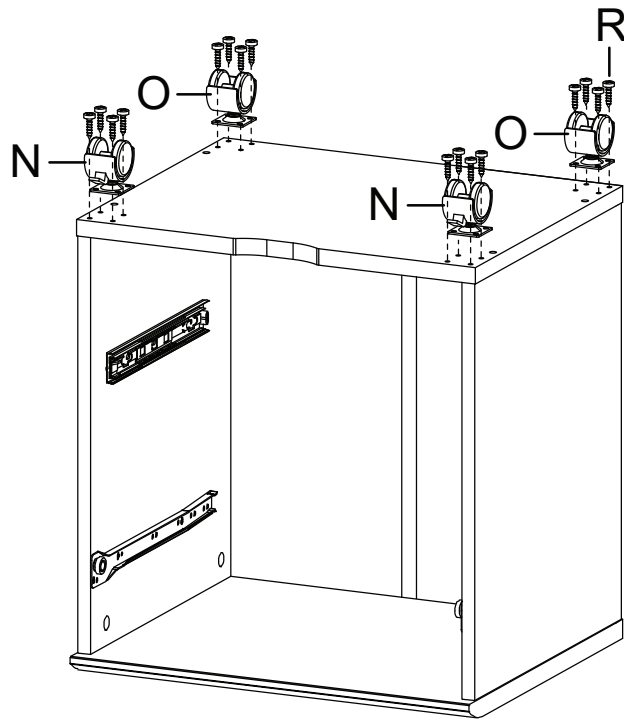

# Step 6

## HARDWARE

- A** Cam Bolt  $\varnothing 6 \times 35$  mm x2
- E** Wood Dowel  $\varnothing 6 \times 30$  mm x2

## COMPONENTS

- 5** Front Drawer Small x1
- 6** Side Drawer Left Small x1
- 7** Side Drawer Right Small x1

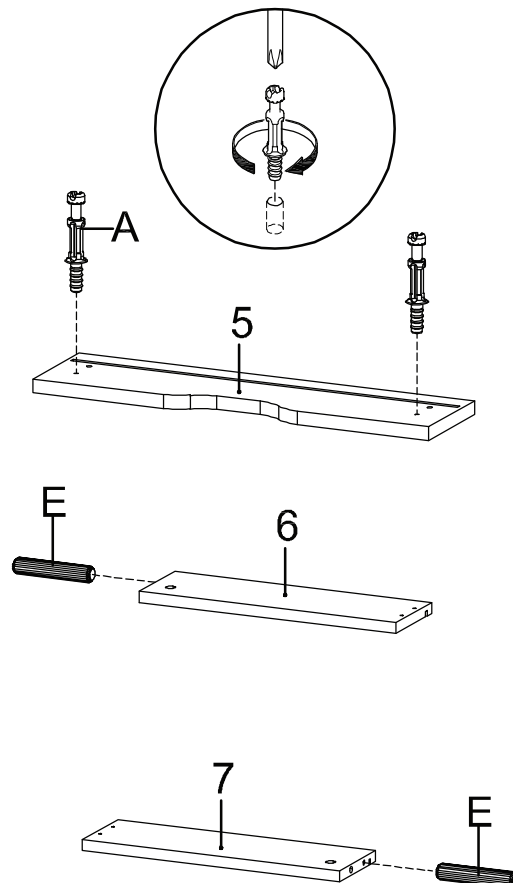

# Step 7

## HARDWARE

- C** Cam Lock Ø12 mm x2
- I** Screw M 8 x 39 mm x4

## COMPONENTS

- 5** Front Drawer Small x1
- 6** Side Drawer Left Small x1
- 7** Side Drawer Right Small x1
- 8** Back Drawer Small x1
- 9** Bottom Drawer x1

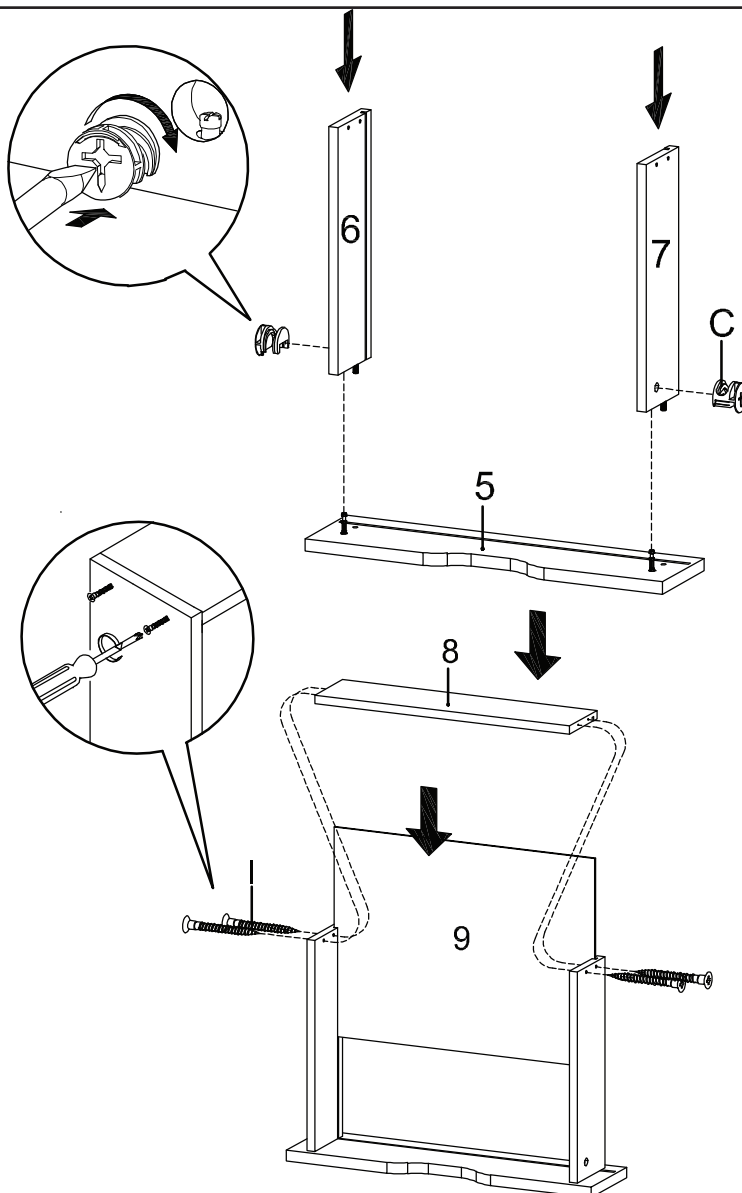

# Step 8

## HARDWARE

- J** Screw M 3.5 x 13 mm x6
- P** Screw M 3.5 x 15.5 mm x4
- Q** Wedge x4
- RM30A** Drawer Runner x1

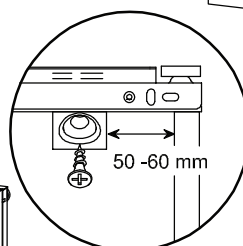
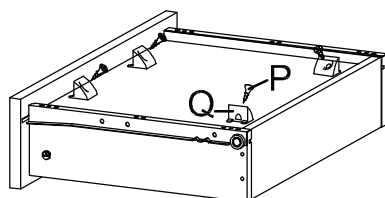
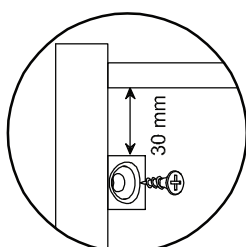
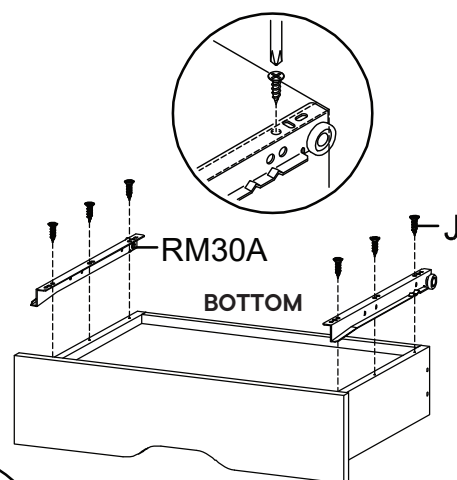

# Step 9

## HARDWARE

- A** Cam Bolt Ø6 x 35 mm x4
- E** Wood Dowel Ø6x30 mm x2
- H** Screw M 6 x 10.5 mm x4
- RB24A** Drawer Runner x1

## COMPONENTS

- 10** Front Drawer Big x1
- 11** Side Drawer Left Big x1
- 12** Side Drawer Right Big x1

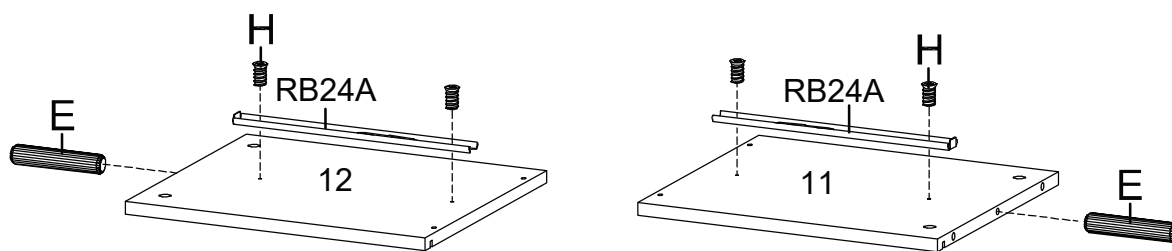
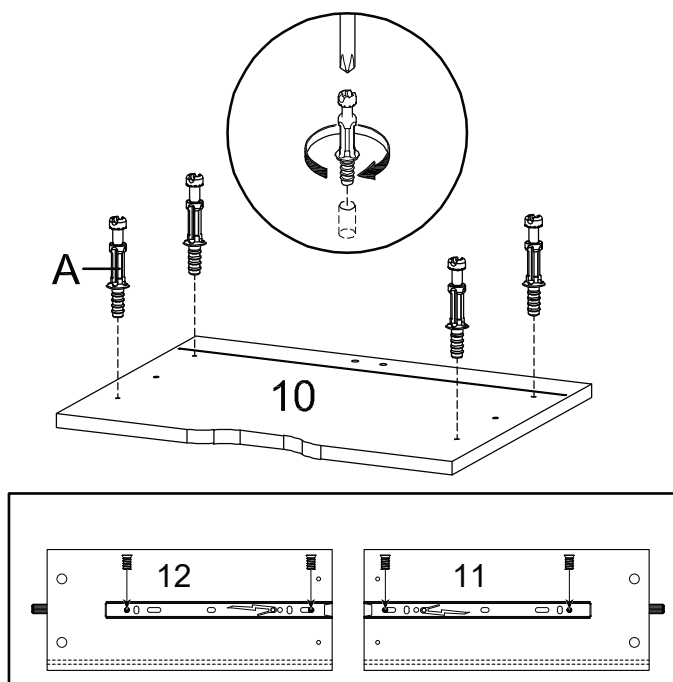

# Step 10

## HARDWARE

- C** Cam Lock Ø12 mm x4
- I** Screw M 8 x 39 mm x4

## COMPONENTS

- 9** Bottom Drawer x1
- 10** Front Drawer Big x1
- 11** Side Drawer Left Big x1
- 12** Side Drawer Right Big x1
- 13** Back Drawer Big x1

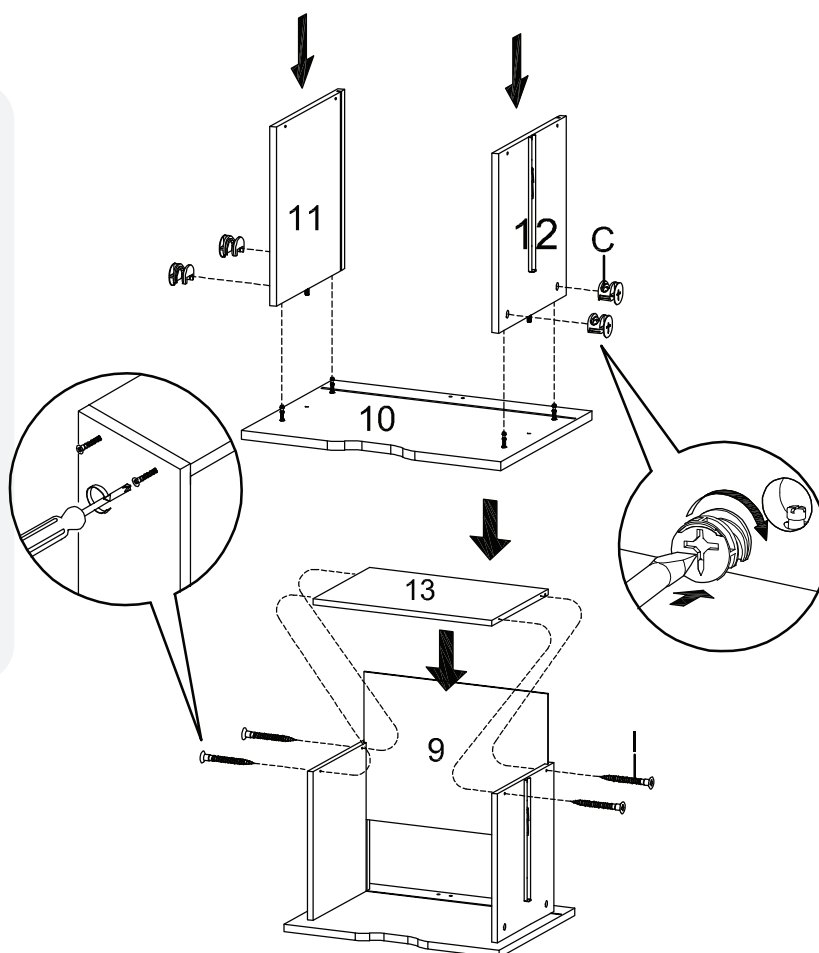

# Step 11

## HARDWARE

- G** Castor With Plate x1
- J** Screw M 3.5 x 13 mm x2
- M** File Hang Rail x2
- P** Screw M 3.5 x 15.5 mm x4
- Q** Wedge x4

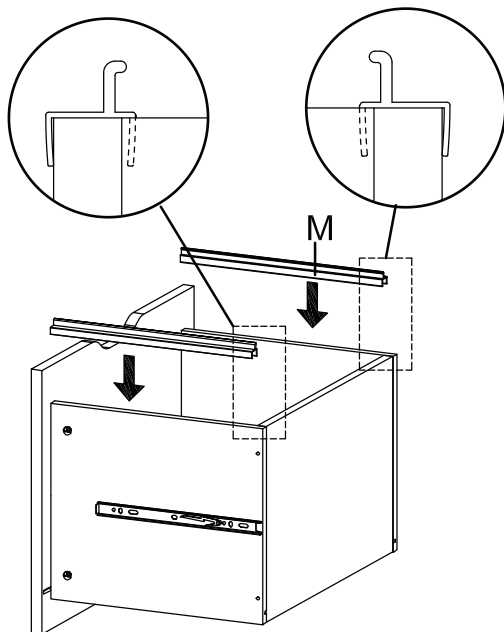
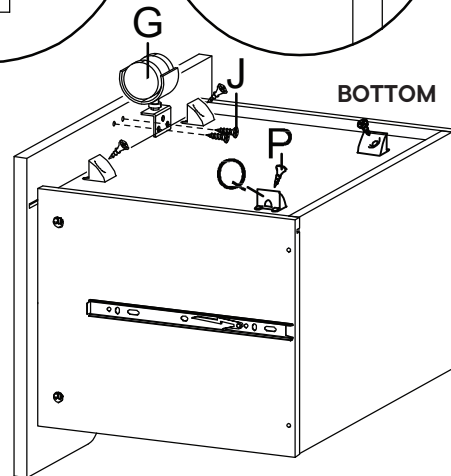
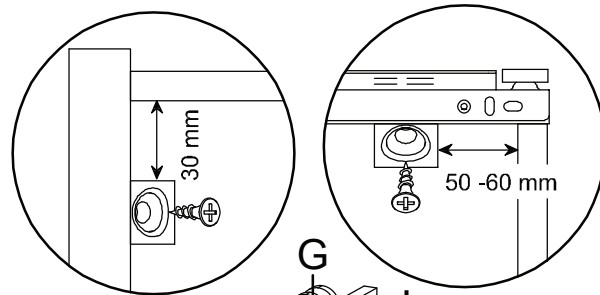

# Step 12

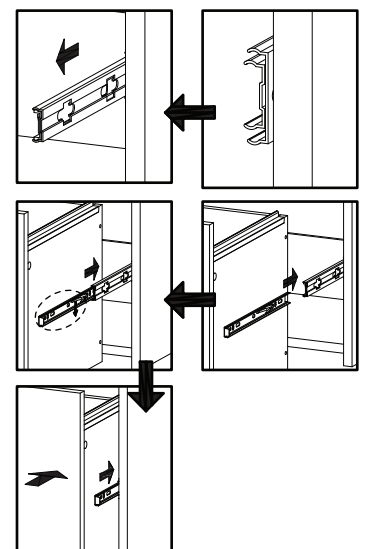
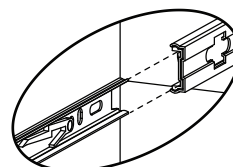
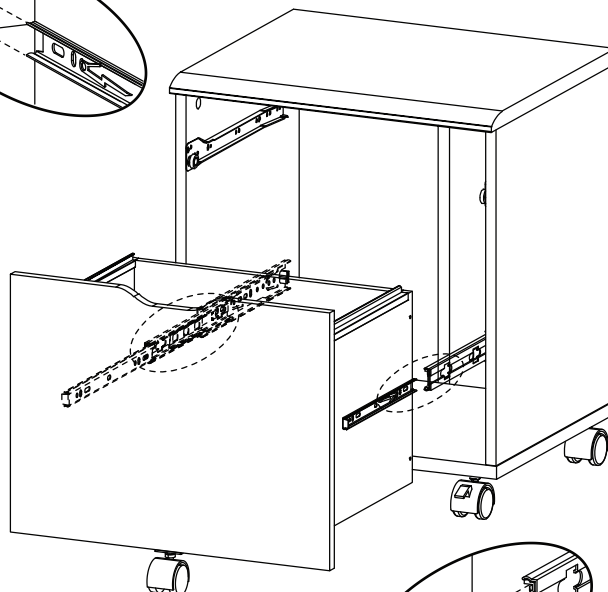
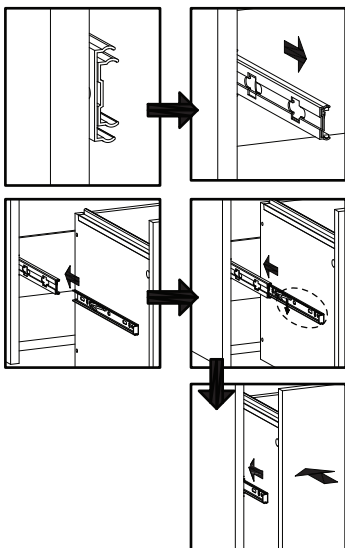
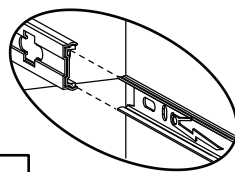

## Step 13

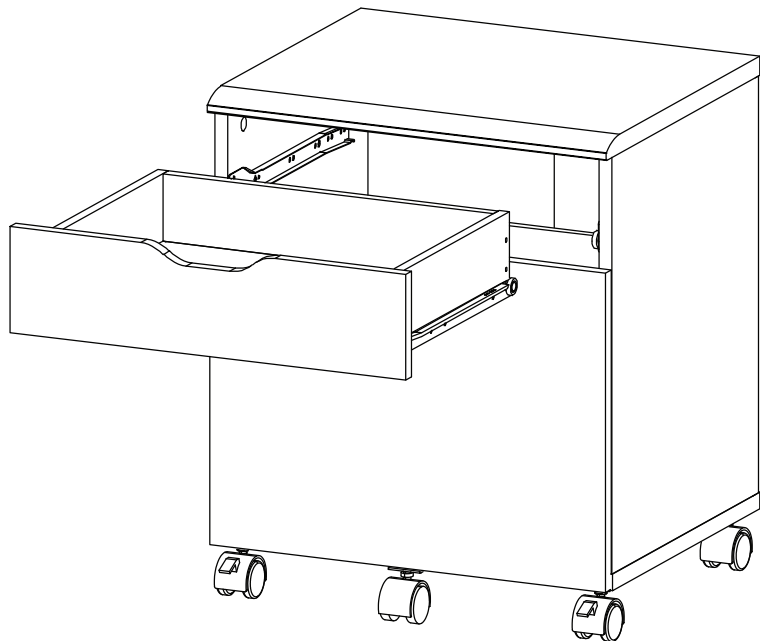
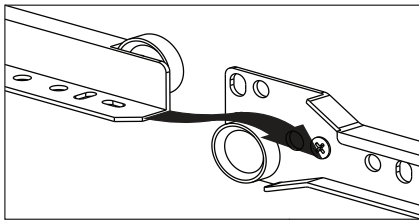

## Step 14

### HARDWARE

- P** Screw M 3.5 x 15.5 mm      x6
- Q** Wedge      x6

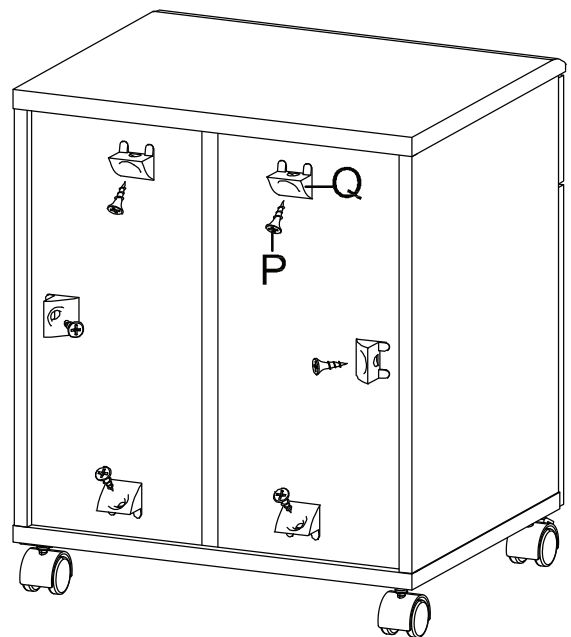
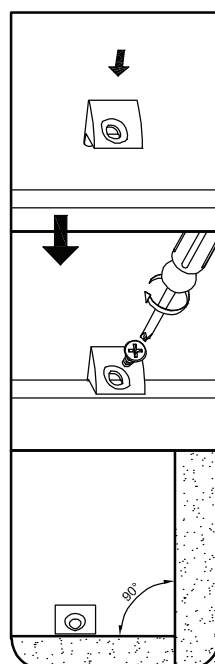

# Great job!

Trolley assembly is complete

## ♥ CARING FOR YOUR ITEM

Indoor use only.

Not contract grade.

Clean using a non-abrasive cloth and a mild cleaner.

Never use harsh chemicals, as they could damage the finish or integrity of the item.

CONNECT WITH US!   

Tag us [@modway\\_furniture](#) and [#modway](#) for a chance to be featured.

