

ASSEMBLY INSTRUCTIONS

EEI-5703

V0.08.04.21

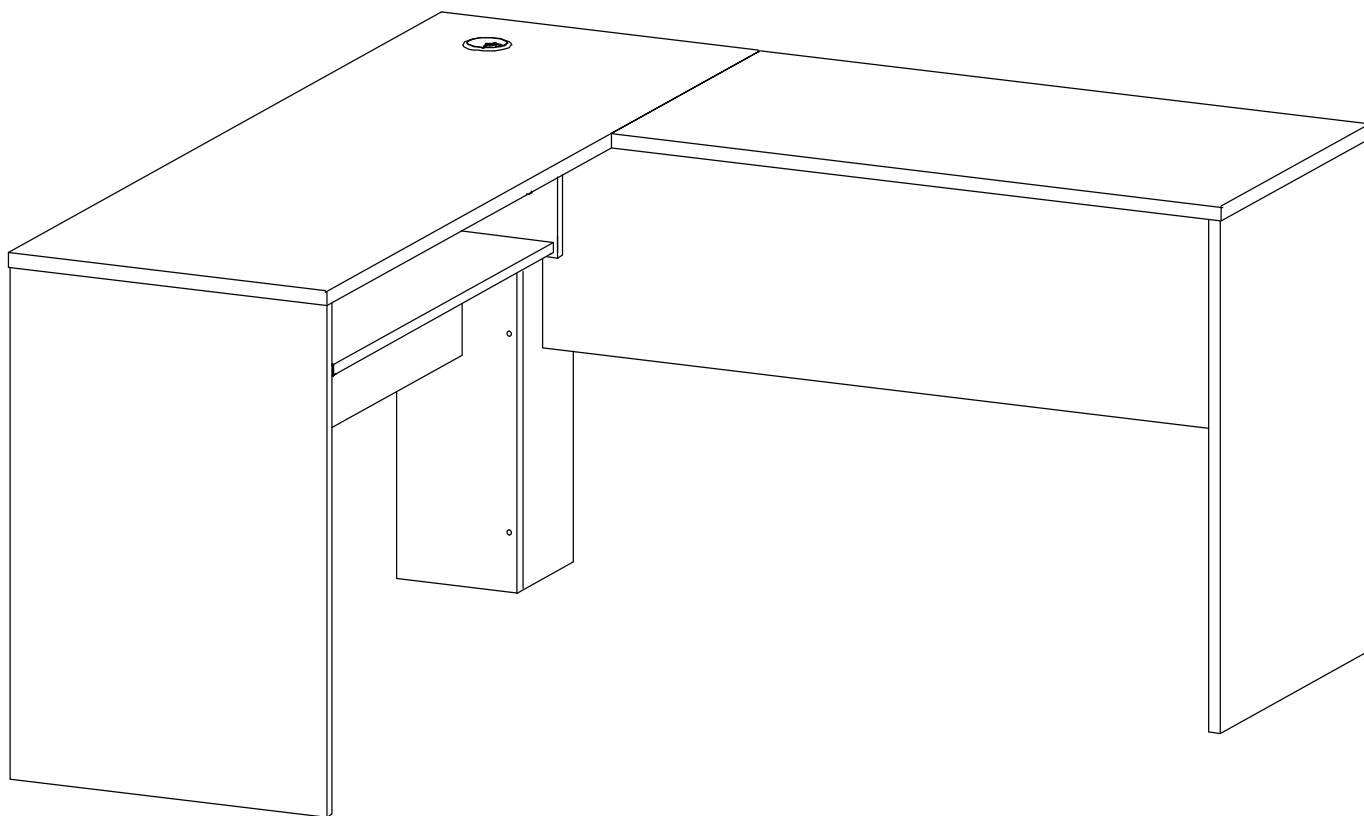

Questions? Contact us!

609.256.9000 • cs@modway.com
www.modway.com

***modway**



Read through all of the instructions before starting



Care instructions are listed in the last step of this manual

Only use hand tools to assemble this item. Do not use power tools. Do not tighten bolts or screws completely until all hardware is lined up and inserted into the holes.



Approx. 90 minutes assembly time



Make sure you have all parts and components before discarding any packing materials

Do not over-tighten screws and bolts to avoid stripping the hardware or cracking the item.

Assemble your item on a flat, carpeted area, with plenty of space to work. This will prevent damage and scratches to your floors or the item while you're assembling the product.



2 people recommended for assembly

Keep all components and packaging out of reach of children or animals to avoid risk of choking or suffocation.

Furniture components:

1	Top Board 1	x1
2	Top Board 2	x1
3	Side Board Left	x1
4	Side Board Right	x1
5	Center Board 1	x1
6	Center Board 2	x1
7	Center Board 3	x1
8	Keyboard Drawer Base	x1
9	Back Board 1	x1
10	Back Board 2	x1

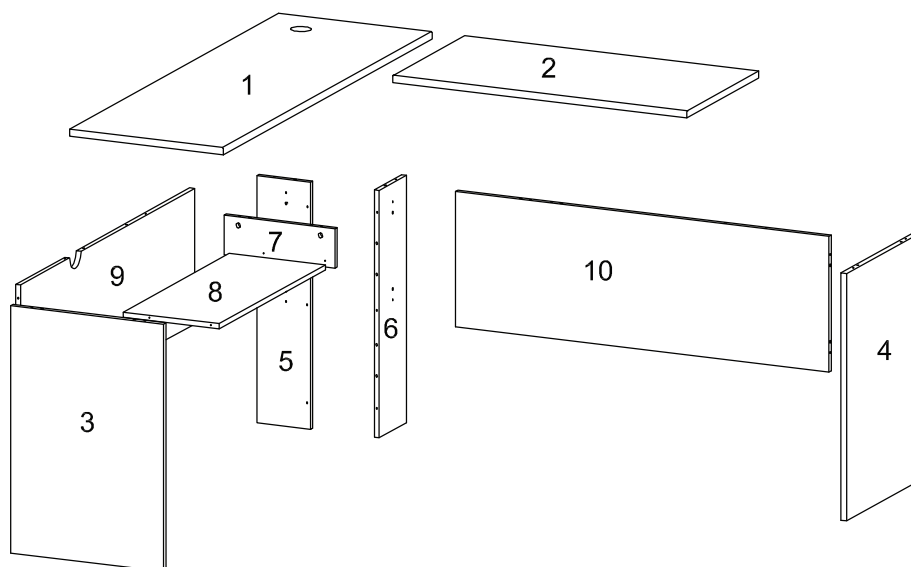

Provided hardware:

A		Cam Bolt $\varnothing 6 \times 35$ mm	x19
B		Cam Lock $\varnothing 15$ mm	x19
C		Wood Dowel $\varnothing 8 \times 30$ mm	x25
D		Screw M 6 x 10.5 mm	x8
E		Screw M 4.5 x 12.5 mm	x12
F		Grommet Cover	x1
G		Screw M 7 x 50 mm	x8
H		Allen Key	x1
I		Mending Plates	x2

What you need:

J		Screw Cap $\varnothing 15$ mm	x15
K		Screw Cap $\varnothing 15$ mm	x4
L		Shoe Plate	x6
RB25A		Keyboard Drawer Runner	x1

Phillips Head Screwdriver

Wait!

Missing parts or hardware? Need assistance?
Contact us before returning your item. We're here to help!
609.256.9000 • cs@modway.com

Step 1

HARDWARE

- C** Wood Dowel Ø8x30 mm x6
- L** Shoe Plate x2

COMPONENTS

- 5** Center Board 1 x1
- 6** Center Board 2 x1

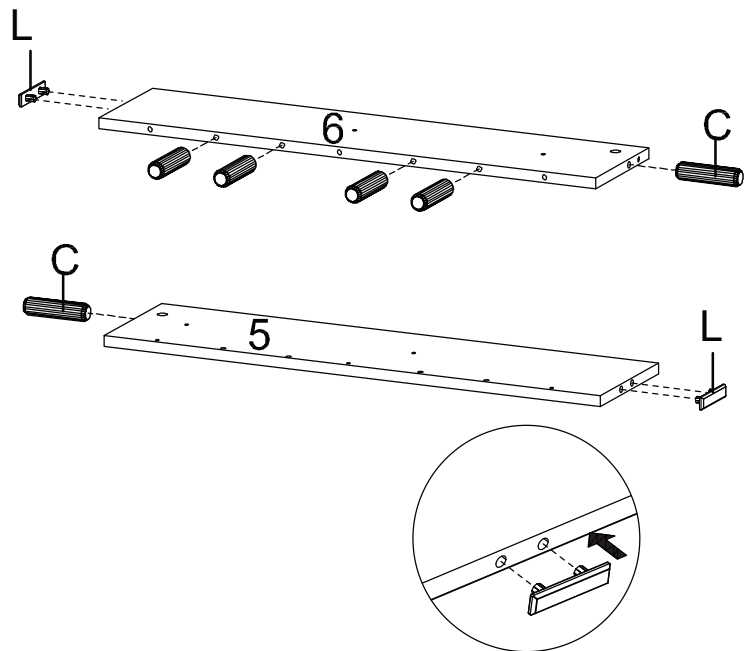

Step 2

HARDWARE

- G** Screw M 7 x 50 mm x3
- H** Allen Key x1

COMPONENTS

- 5** Center Board 1 x1
- 6** Center Board 2 x1

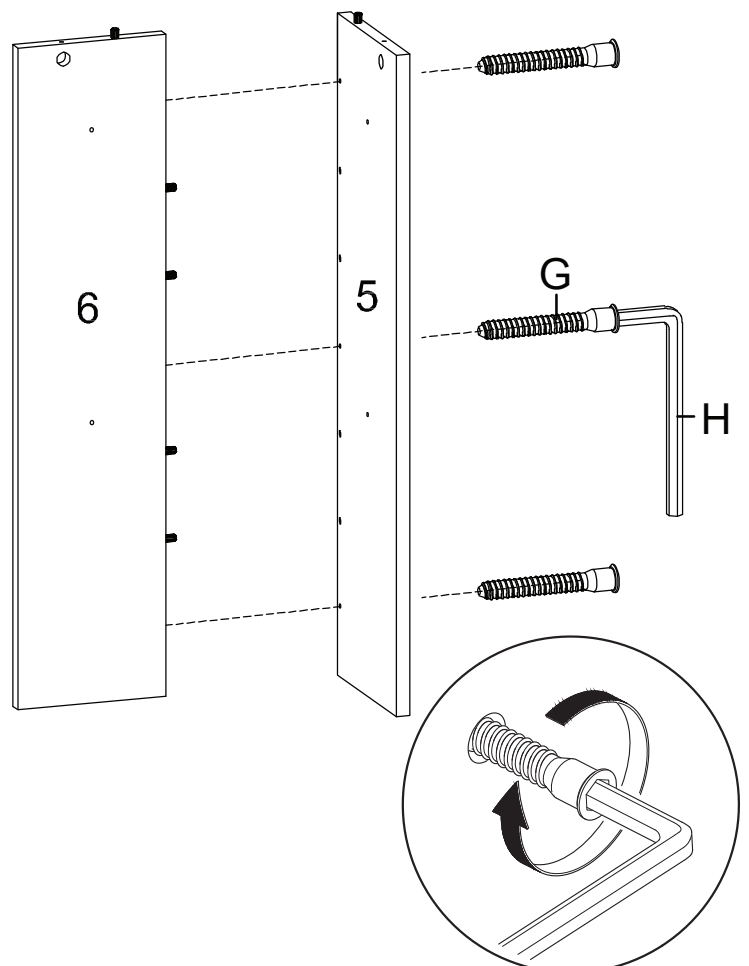

Step 3

HARDWARE

- A** Cam Bolt Ø6 x 35 mm x2
- C** Wood Dowel Ø8x30 mm x10
- D** Screw M 6 x 10.5 mm x4
- RB25A** Keyboard Drawer Runner x1
- L** Shoe Plate x2

COMPONENTS

- 3** Side Board Left x1
- 7** Center Board 3 x1
- 9** Back Board 1 x1

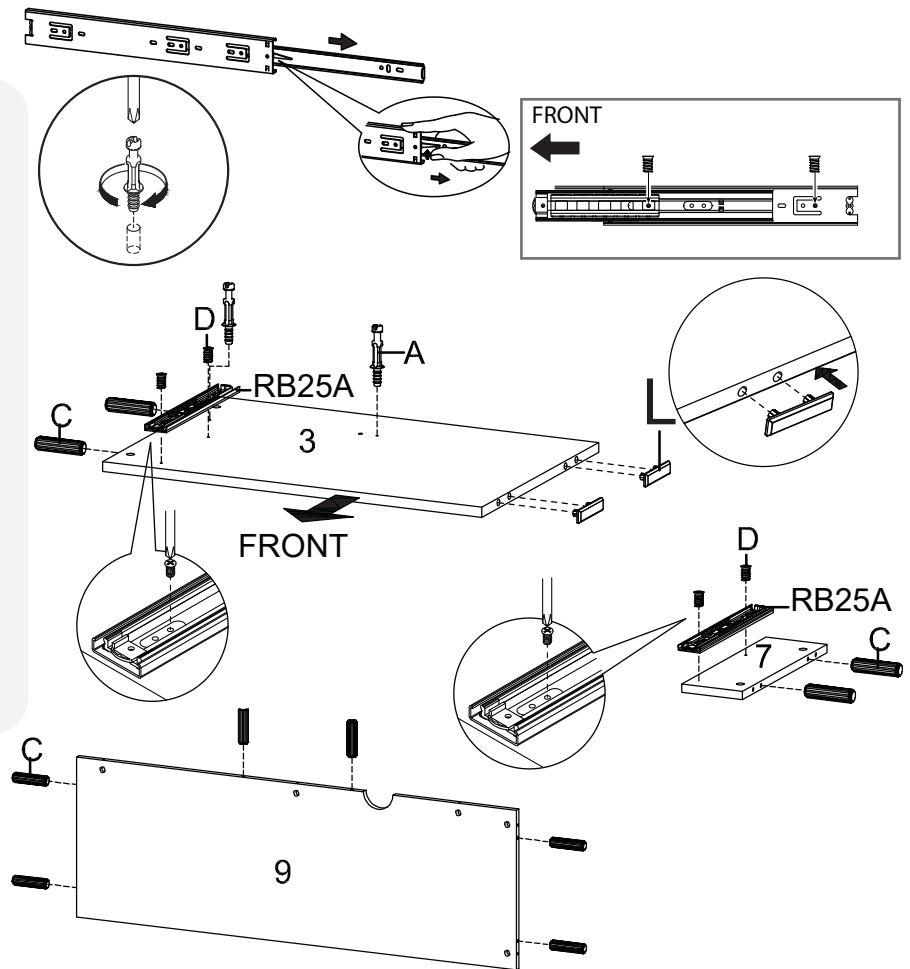

Step 4

HARDWARE

- B** Cam Lock Ø15 mm x2
- J** Screw Cap Ø15 mm x2

COMPONENTS

- 3** Side Board Left x1
- 9** Back Board 1 x1

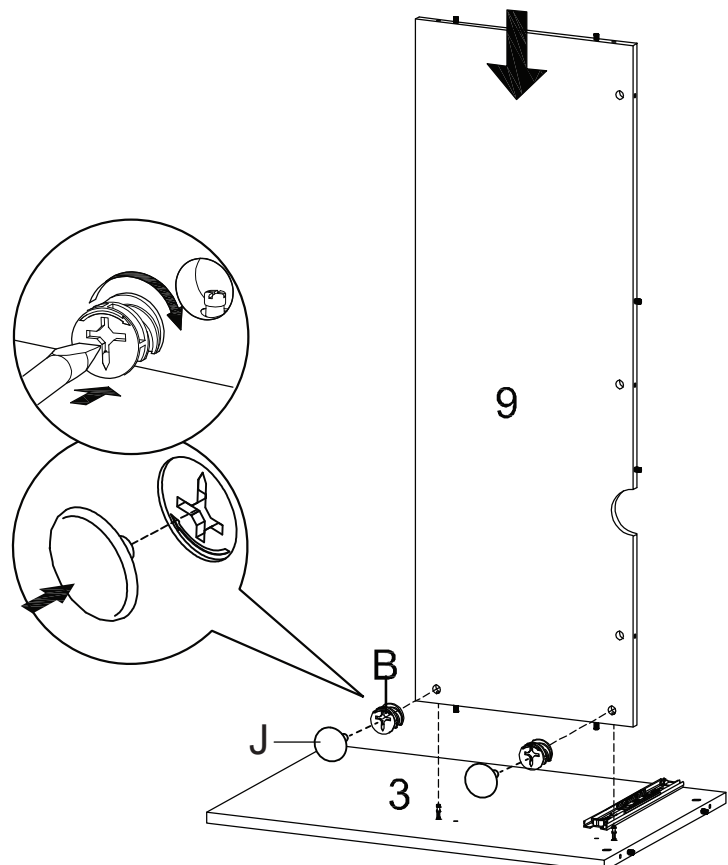

Step 5

HARDWARE

- G** Screw M 7 x 50 mm x2
- H** Allen Key x1

COMPONENTS

- 3** Side Board Left x1
- 9** Back Board 1 x1

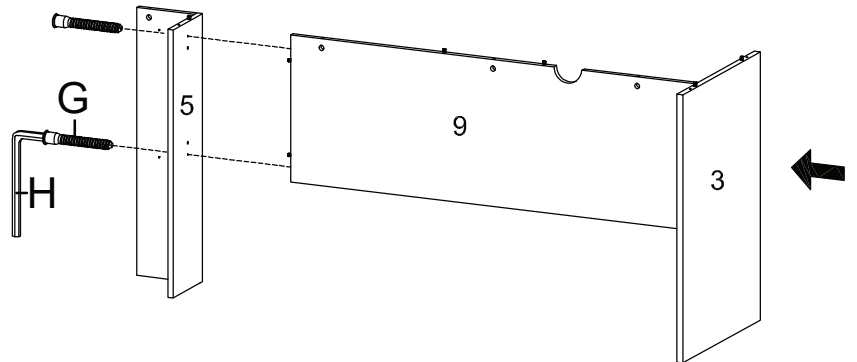
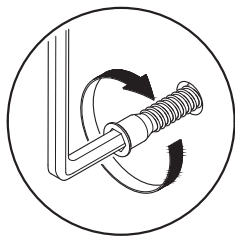

Step 6

HARDWARE

- A** Cam Bolt $\varnothing 6 \times 35$ mm x2
- C** Wood Dowel $\varnothing 8 \times 30$ mm x9
- L** Shoe Plate x2

COMPONENTS

- 4** Side Board Right x1
- 10** Back Board 2 x1

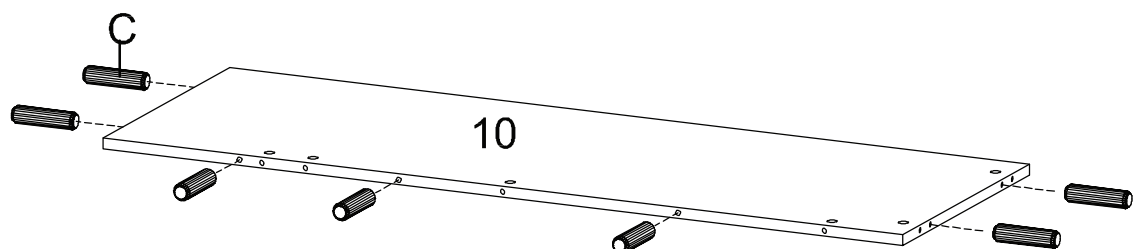
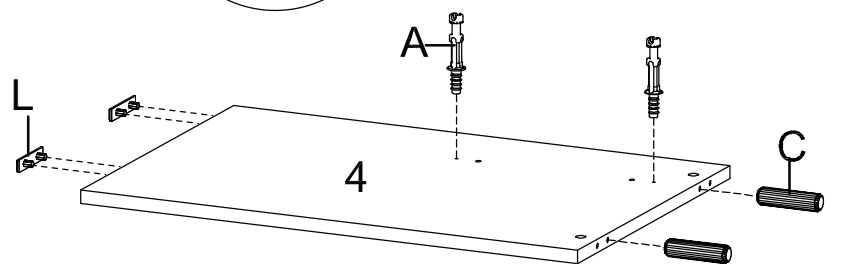
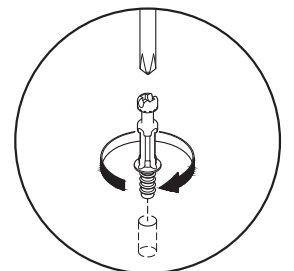
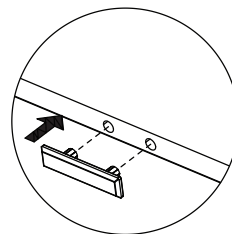

Step 7

HARDWARE

- B** Cam Lock Ø15 mm x2
- J** Screw Cap Ø15 mm x2

COMPONENTS

- 4** Side Board Right x1
- 10** Back Board 2 x1

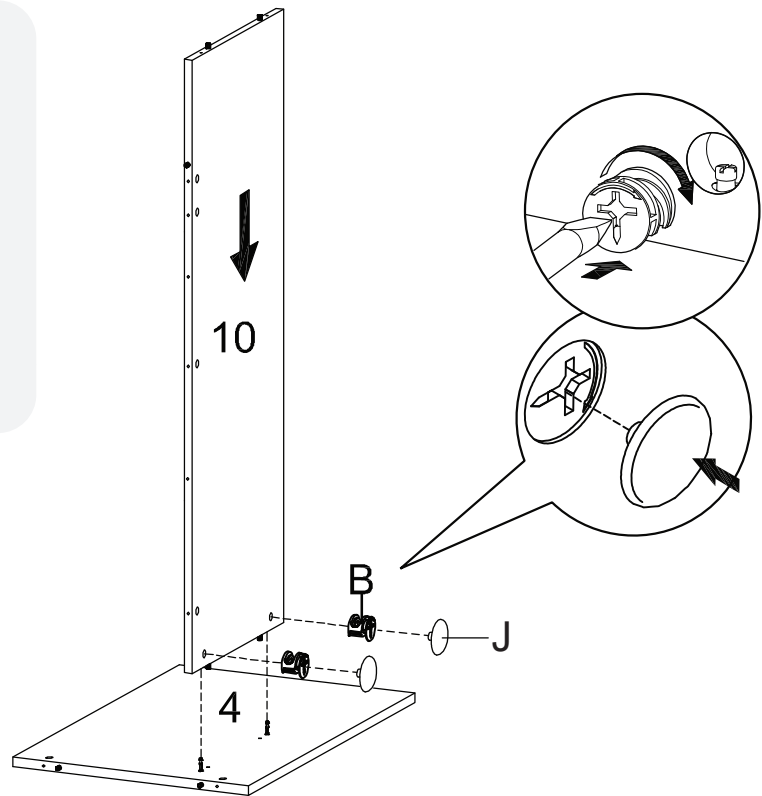

Step 8

HARDWARE

- G** Screw M 7 x 50 mm x2
- H** Allen Key x1

COMPONENTS

- 4** Side Board Right x1
- 10** Back Board 2 x1

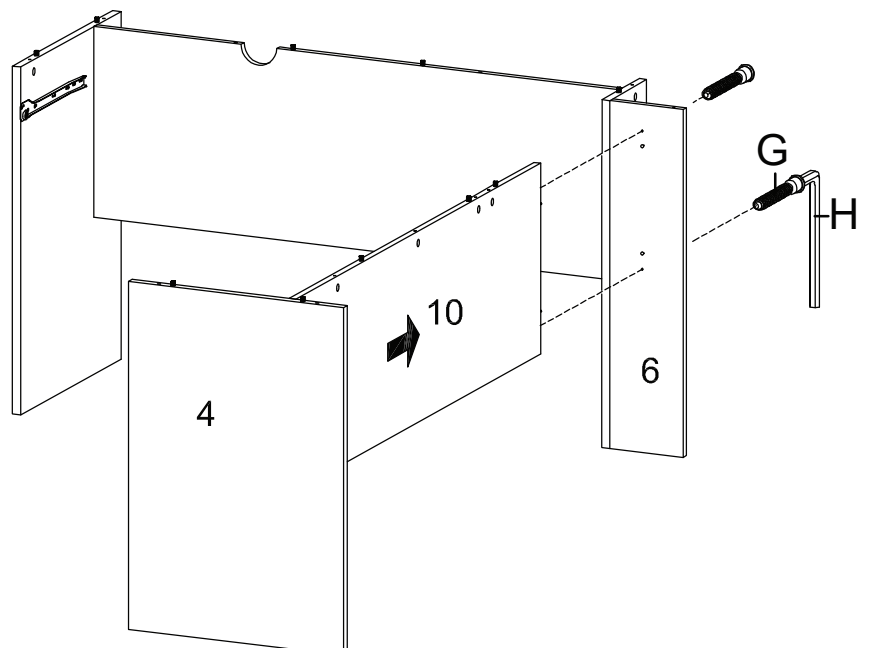

Step 9

HARDWARE

- A** Cam Bolt $\varnothing 6 \times 35$ mm x15
- I** Mending Plates x2
- E** Screw M 4.5 x 12.5 mm x6

COMPONENTS

- 1** Top Board 1 x1
- 2** Top Board 2 x1

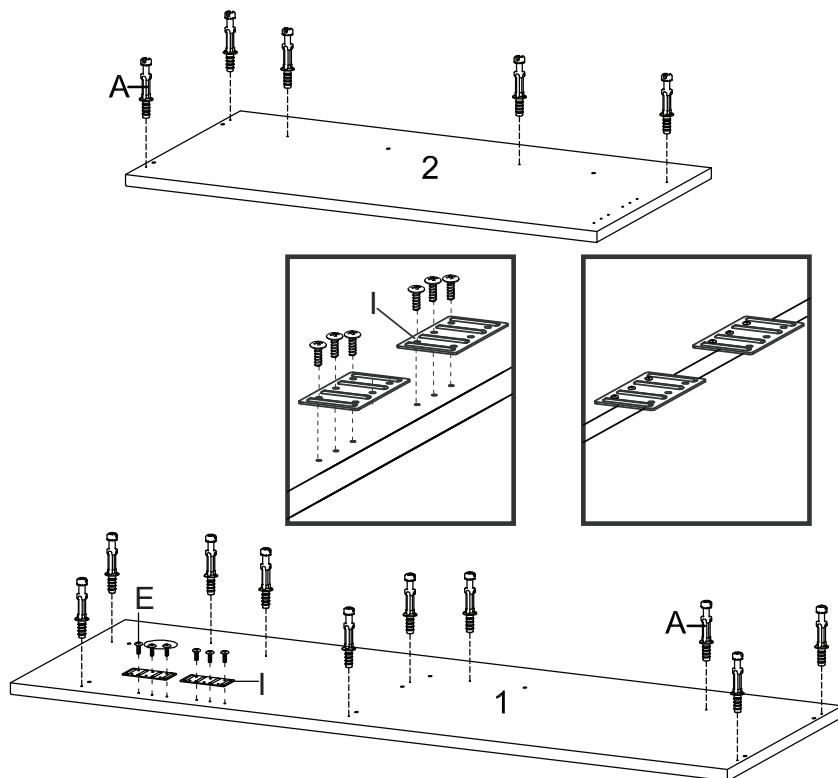

Step 10

HARDWARE

- B** Cam Lock $\varnothing 15$ mm x8
- J** Screw Cap $\varnothing 15$ mm x6
- K** Screw Cap $\varnothing 15$ mm x2

COMPONENTS

- 1** Top Board 1 x1

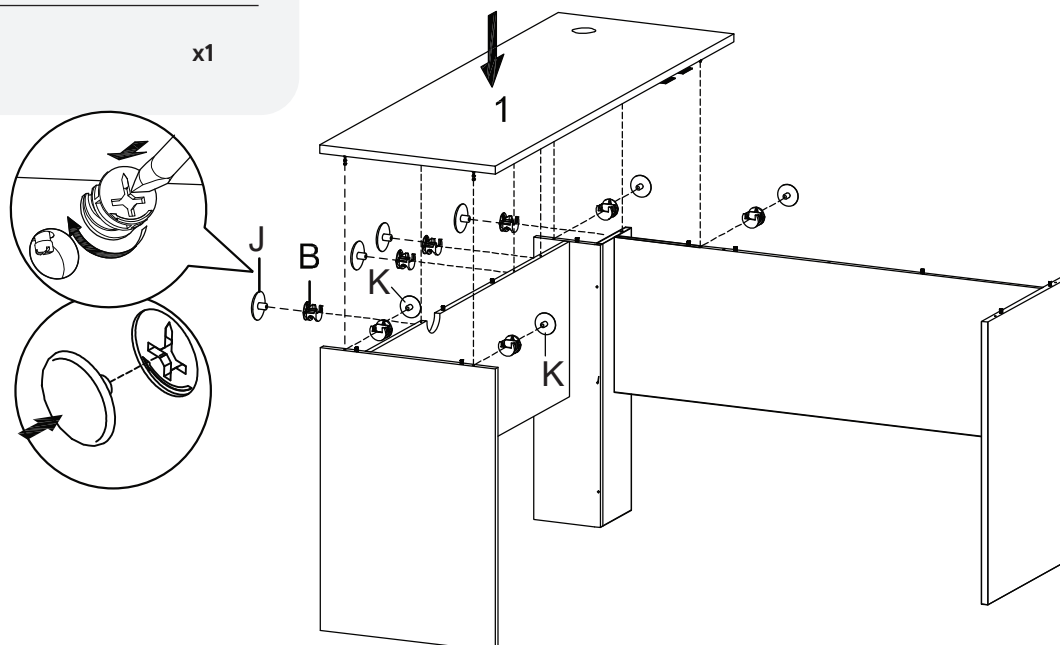

Step 11

HARDWARE

- B** Cam Lock Ø15 mm x5
- J** Screw Cap Ø15 mm x3
- K** Screw Cap Ø15 mm x2

COMPONENTS

- 2** Top Board 2 x1

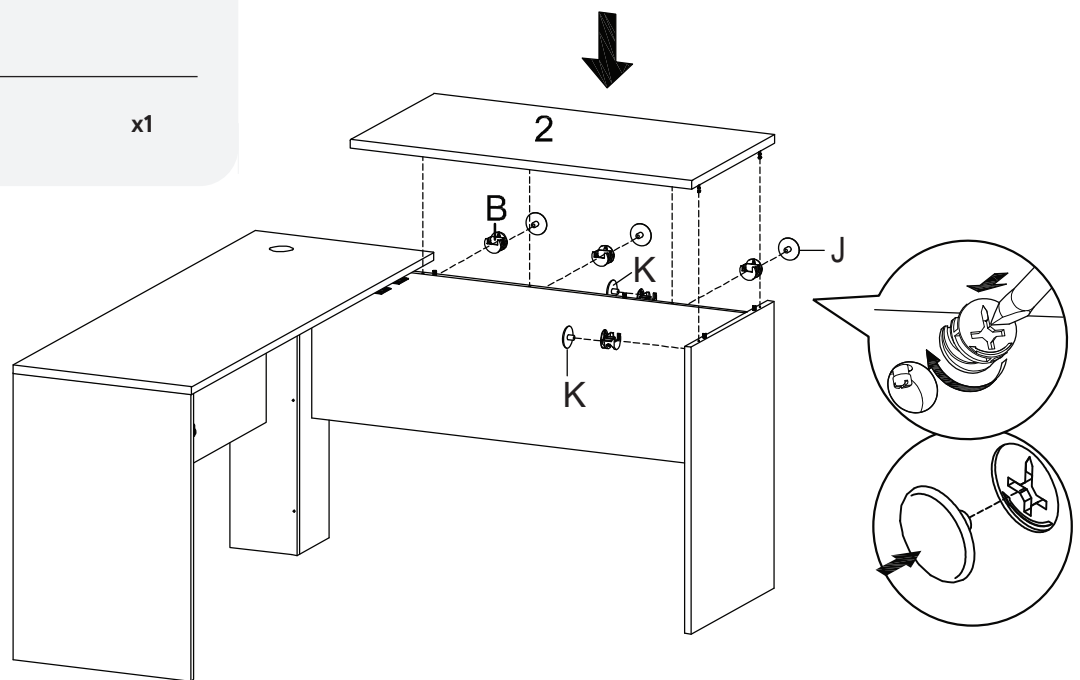

Step 12

HARDWARE

- E** Screw M 4.5 x 12.5 mm x6

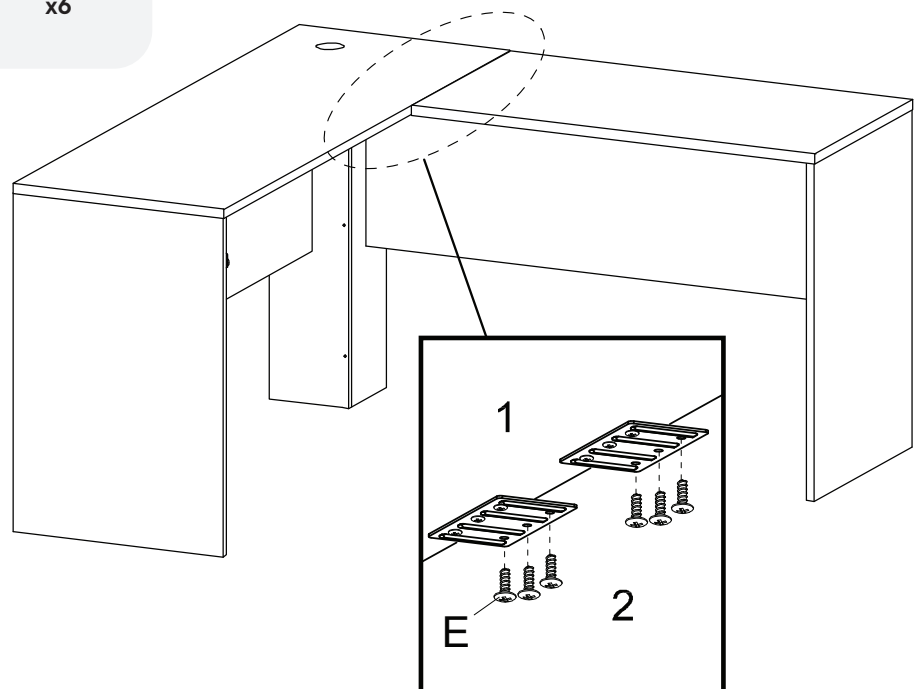

Step 13

HARDWARE

- B** Cam Lock Ø15 mm x2
- J** Screw Cap Ø15 mm x2

COMPONENTS

- 7** Center Board 3 x1

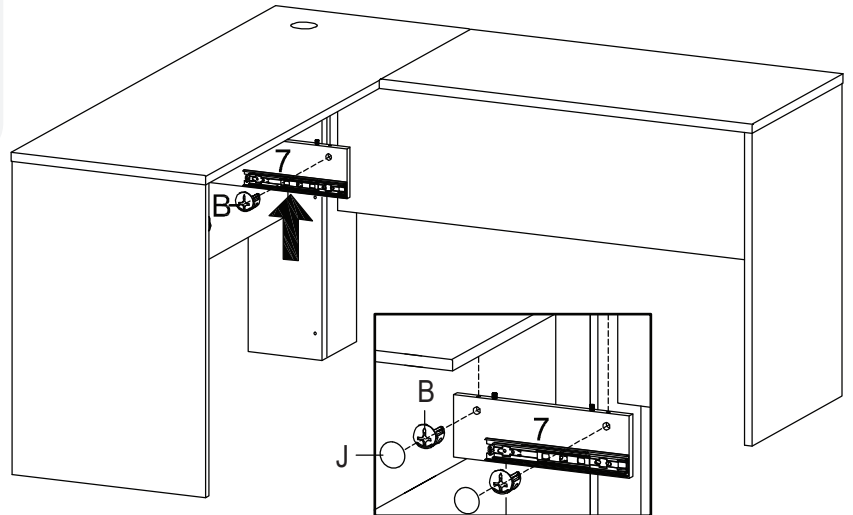

Step 14

HARDWARE

- G** Screw M 7 x 50 mm x1
- H** Allen Key x1

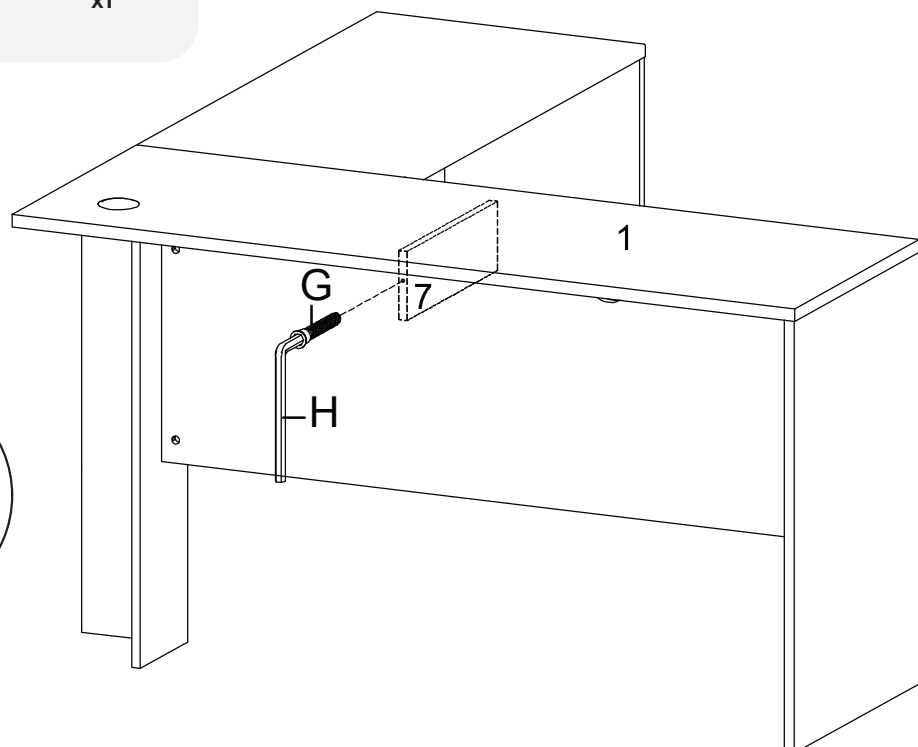
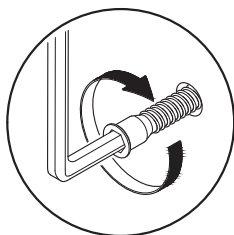

Step 15

HARDWARE

- D** Screw M 6 x 10.5 mm x4
- RB25A** Keyboard Drawer Runner x1

COMPONENTS

- 8** Keyboard Drawer Base x1

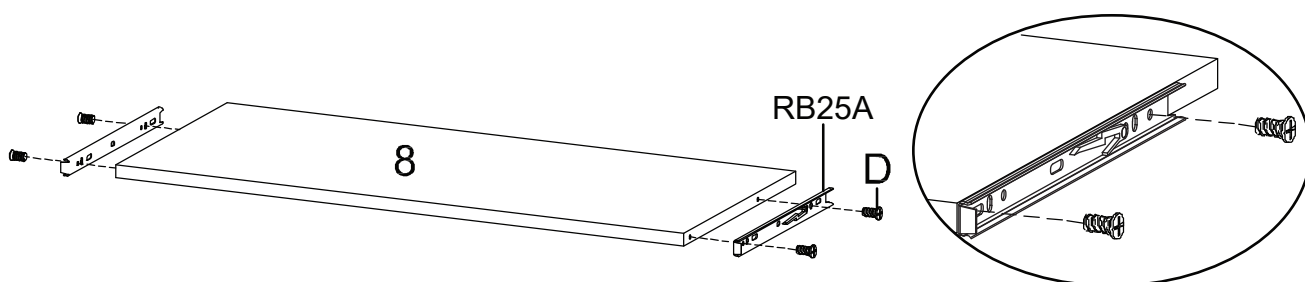
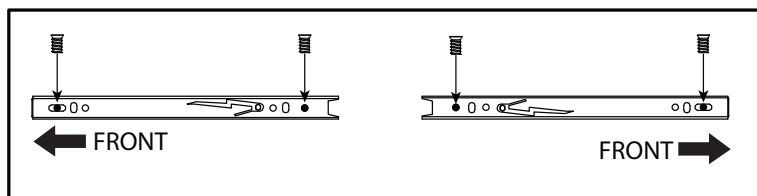

Step 16

HARDWARE

- F** Grommet Cover x1

COMPONENTS

- 8** Keyboard Drawer Base x1

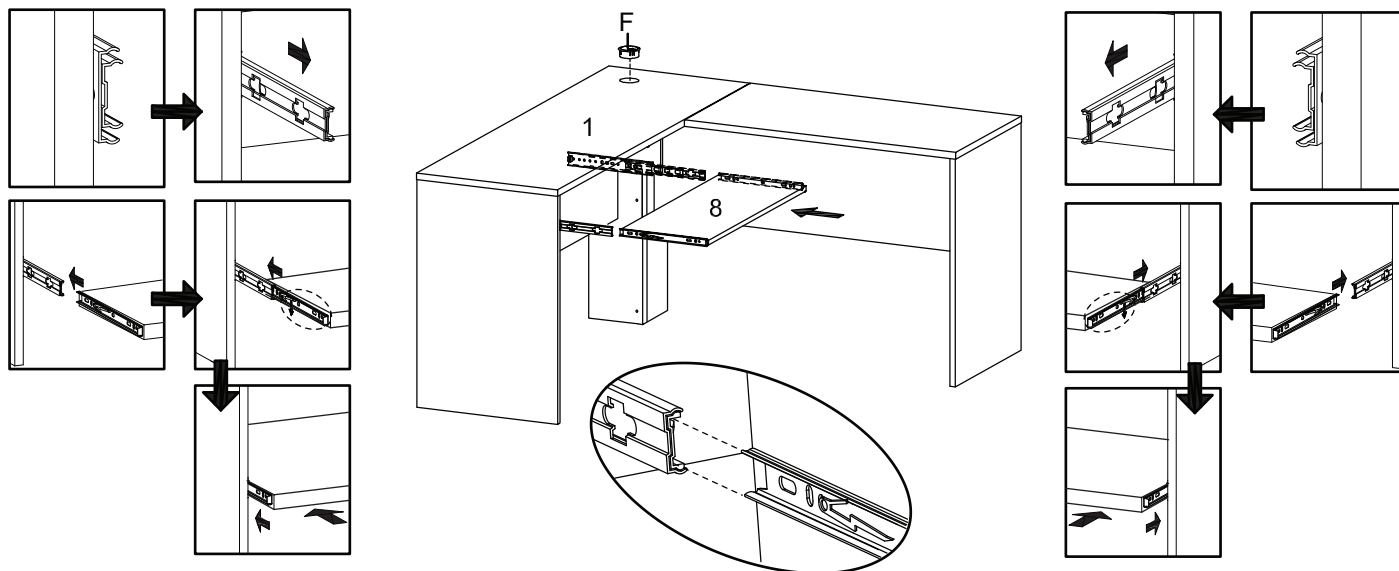

Great job!

Desk assembly is complete

♥ CARING FOR YOUR ITEM

Indoor use only.

Not contract grade.

Clean using a non-abrasive cloth and a mild cleaner.

Never use harsh chemicals, as they could damage the finish or integrity of the item.

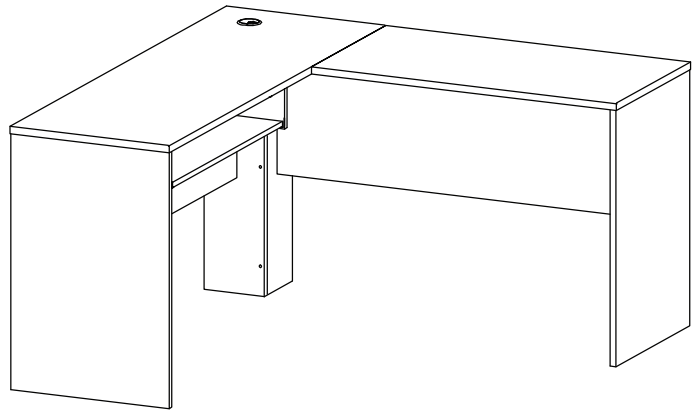

CONNECT WITH US!   

Tag us [@modway_furniture](#) and [#modway](#) for a chance to be featured.

ASSEMBLY INSTRUCTIONS

EEI-5705

V0.08.05.21

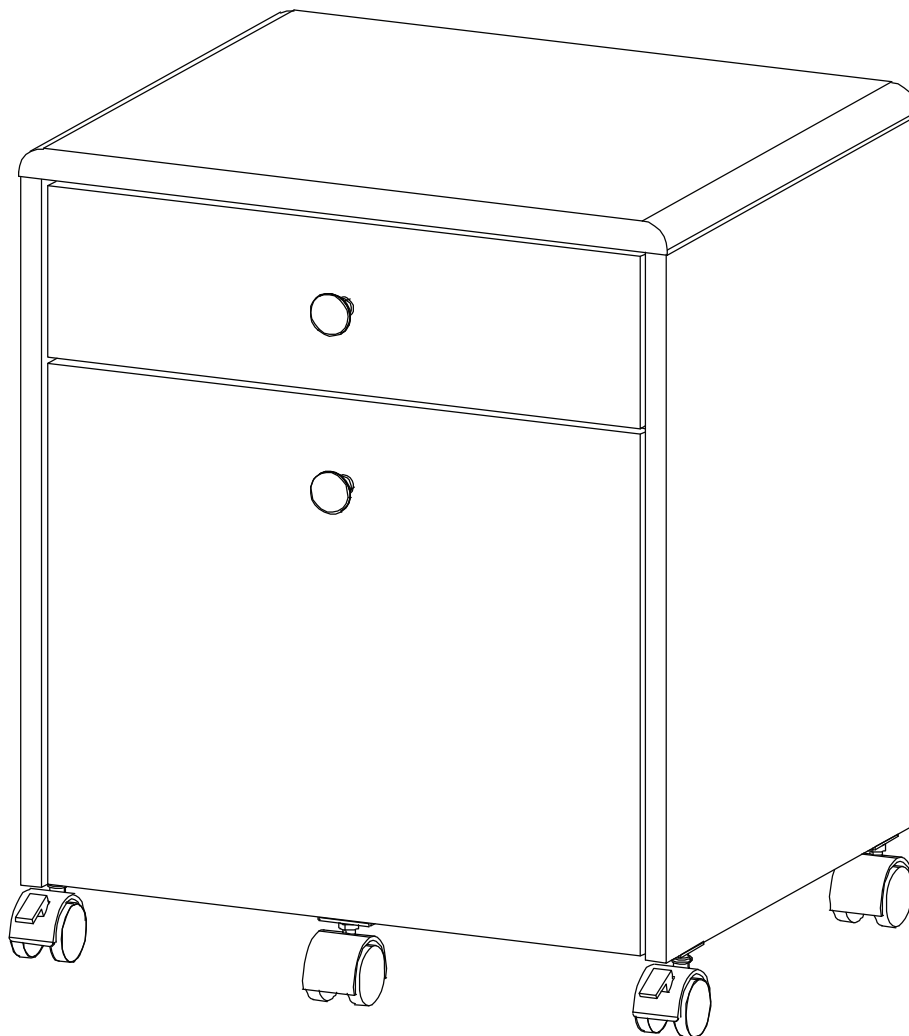

Questions? Contact us!

609.256.9000 • cs@modway.com
www.modway.com

*modway

Let's get started!

*modway



Read through all of the instructions before starting



Care instructions are listed in the last step of this manual



Approx. 90 minutes assembly time



Make sure you have all parts and components before discarding any packing materials



2 people recommended for assembly

Only use hand tools to assemble this item. Do not use power tools. Do not tighten bolts or screws completely until all hardware is lined up and inserted into the holes.

Do not over-tighten screws and bolts to avoid stripping the hardware or cracking the item.

Assemble your item on a flat, carpeted area, with plenty of space to work. This will prevent damage and scratches to your floors or the item while you're assembling the product.

Keep all components and packaging out of reach of children or animals to avoid risk of choking or suffocation.

Furniture components:

1	Top Board	x1	11	Side Drawer Left Big	x1
2	Bottom Board	x1	12	Side Drawer Right Big	x1
3	Side Board Left	x1	13	Back Drawer Big	x1
4	Side Board Right	x1	14	Back Skirt	x1
5	Front Drawer Small	x1	15	Back Board	x1
6	Side Drawer Left Small	x1			
7	Side Drawer Right Small	x1			
8	Back Drawer Small	x1			
9	Bottom Drawer	x2			
10	Front Drawer Big	x1			

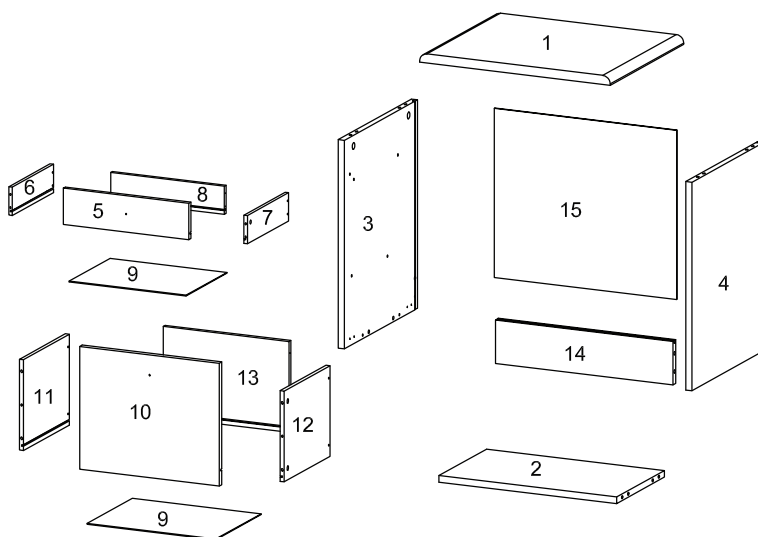

Provided hardware:

A		Cam Bolt $\varnothing 6 \times 35$ mm	x16
B		Cam Lock $\varnothing 15$ mm	x10
C		Cam Lock $\varnothing 12$ mm	x6
D		Wood Dowel $\varnothing 8 \times 30$ mm	x10
E		Wood Dowel $\varnothing 6 \times 30$ mm	x4
F		Screw M 3.5 x 15.5 mm	x14
G		Wedge	x14
H		Screw M 6 x 10.5 mm	x14
I		Screw M 8 x 39 mm	x8

J		Screw M 3.5 x 13 mm	x16
K		Handle	x2
L		Screw M 4 x 22 mm	x2
M		File Hang Rail	x2
N		Castor With Stopper	x2
O		Castor	x3
RM30A		Drawer Runner	x1
RB24A		Drawer Runner	x1

What you need:

Phillips Head Screwdriver

Wait!

Missing parts or hardware? Need assistance?
Contact us before returning your item. We're here to help!
609.256.9000 • cs@modway.com

Step 1

HARDWARE

- A** Cam Bolt Ø6 x 35 mm x4
- D** Wood Dowel Ø8x30 mm x6

COMPONENTS

- 1** Top Board x1
- 2** Bottom Board x1
- 14** Back Skirt x1

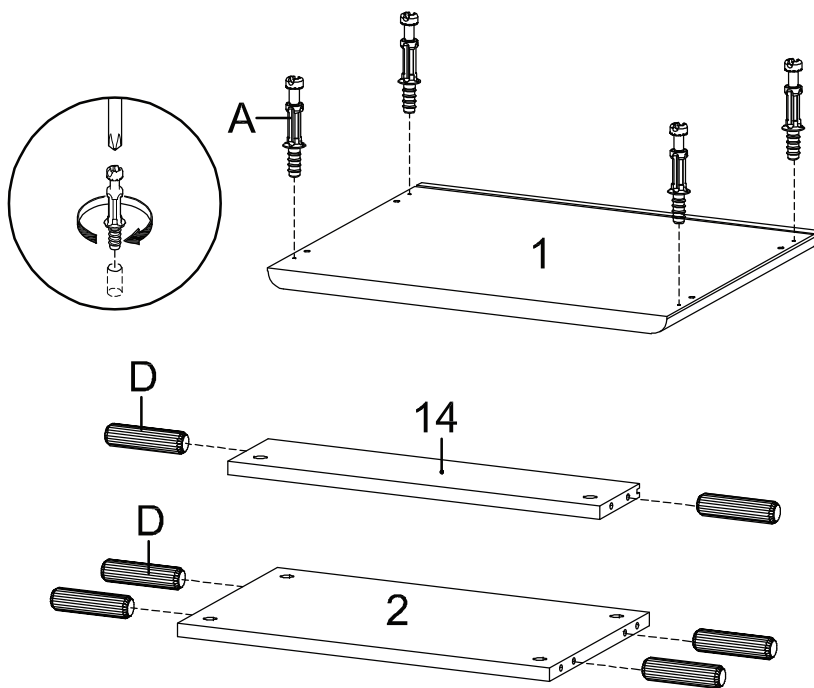

Step 2

HARDWARE

- A** Cam Bolt Ø6 x 35 mm x6
- D** Wood Dowel Ø8x30 mm x4
- H** Screw M 6 x 10.5 mm x10
- J** Screw M 3.5 x 13 mm x8
- N** Castor With Stopper x2
- O** Castor x2
- RM30A** Drawer Runner x1
- RB24A** Drawer Runner x1

COMPONENTS

- 3** Side Board Left x1
- 4** Side Board Right x1

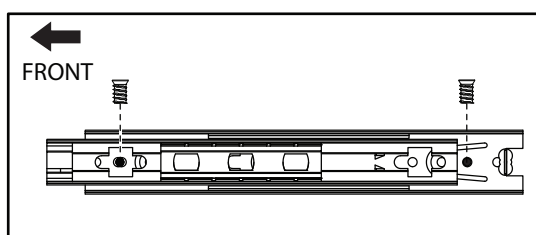
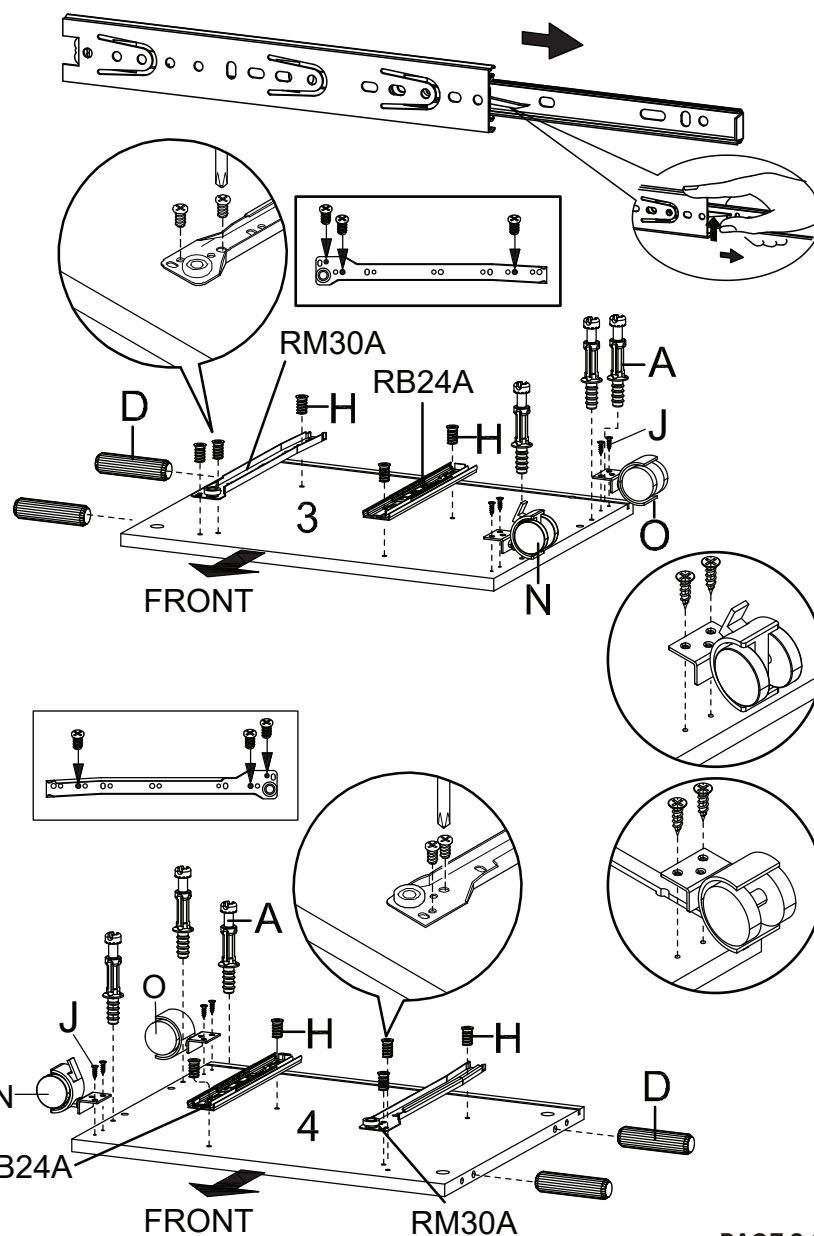

Step 3

HARDWARE

B Cam Lock Ø15 mm x6

COMPONENTS

2 Bottom Board x1

3 Side Board Left x1

4 Side Board Right x1

14 Back Skirt x1

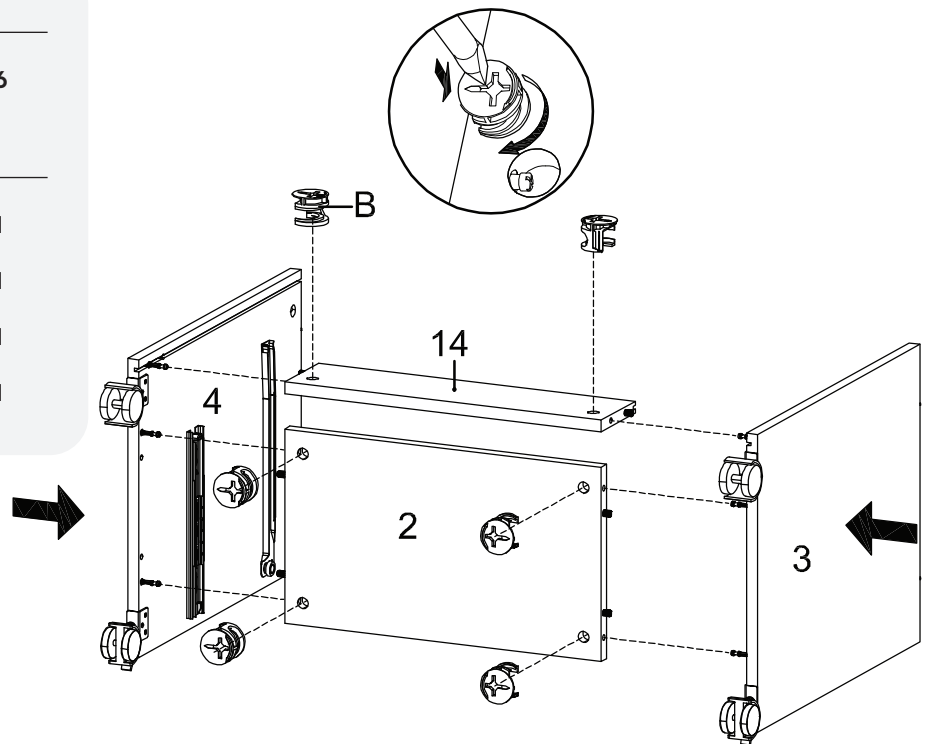

Step 4

HARDWARE

B Cam Lock Ø15 mm x4

COMPONENTS

1 Top Board x1

15 Back Board x1

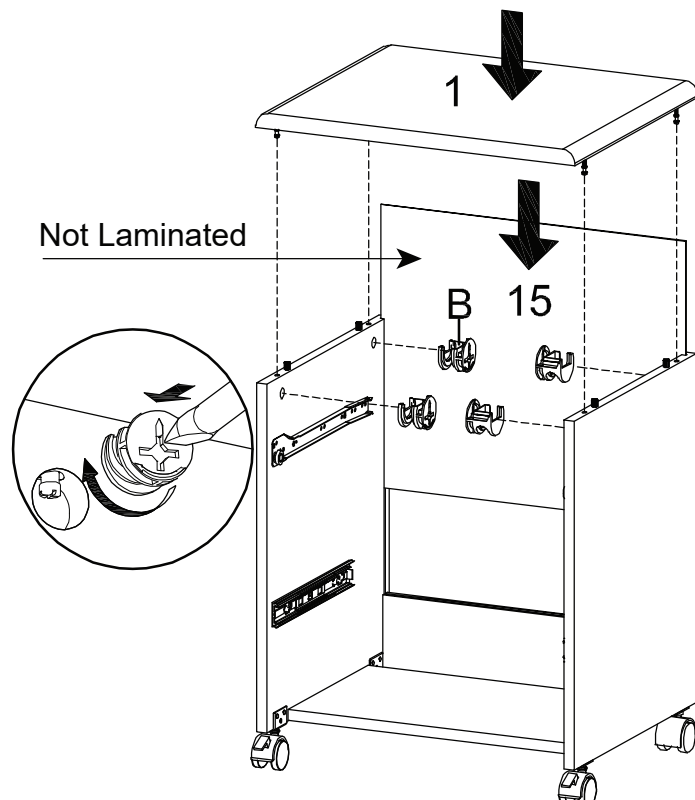

Step 5

HARDWARE

- A** Cam Bolt $\varnothing 6 \times 35$ mm x2
- E** Wood Dowel $\varnothing 6 \times 30$ mm x2

COMPONENTS

- 5** Front Drawer Small x1
- 6** Side Drawer Left Small x1
- 7** Side Drawer Right Small x1

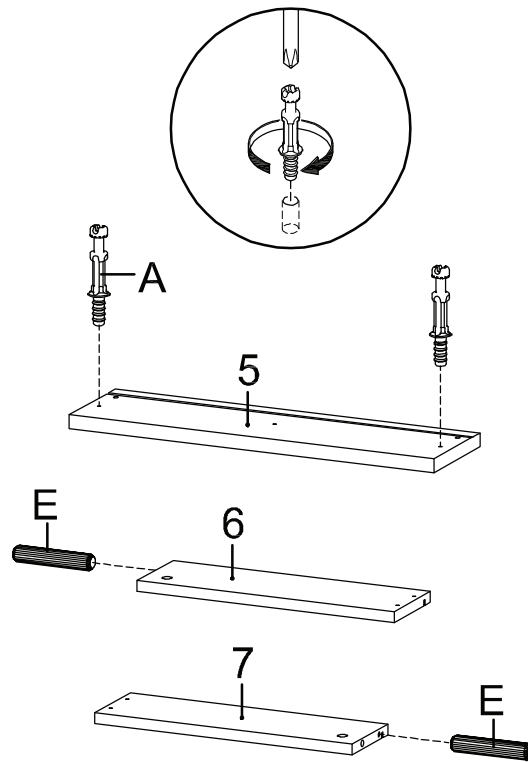

Step 6

HARDWARE

- C** Cam Lock $\varnothing 12$ mm x2
- I** Screw M 8 x 39 mm x4

COMPONENTS

- 5** Front Drawer Small x1
- 6** Side Drawer Left Small x1
- 7** Side Drawer Right Small x1
- 8** Back Drawer Small x1
- 9** Bottom Drawer x1

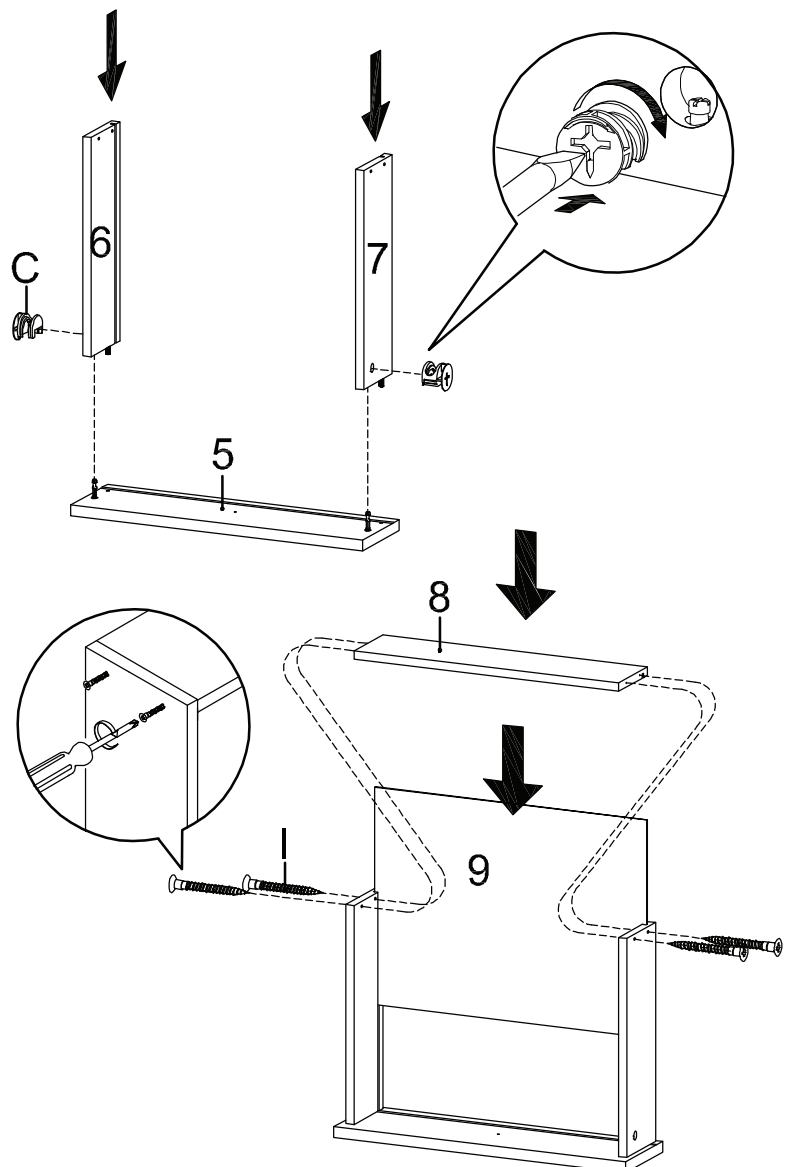

Step 7

HARDWARE

F	Screw M 3.5 x 15.5 mm	x4
G	Wedge	x4
J	Screw M 3.5 x 13 mm	x6
RM30A	Drawer Runner	x1

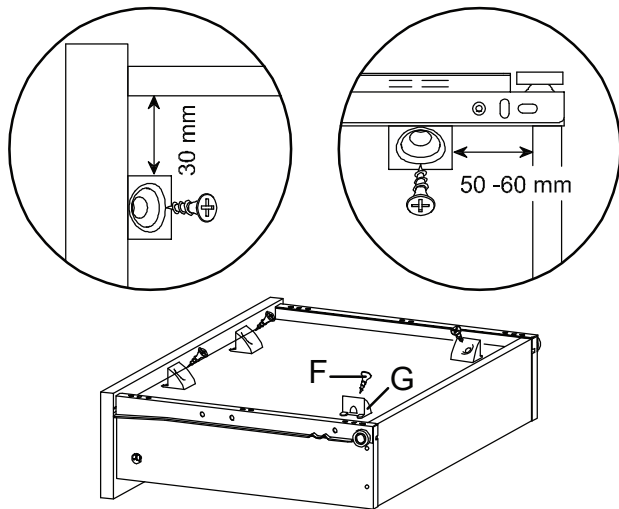
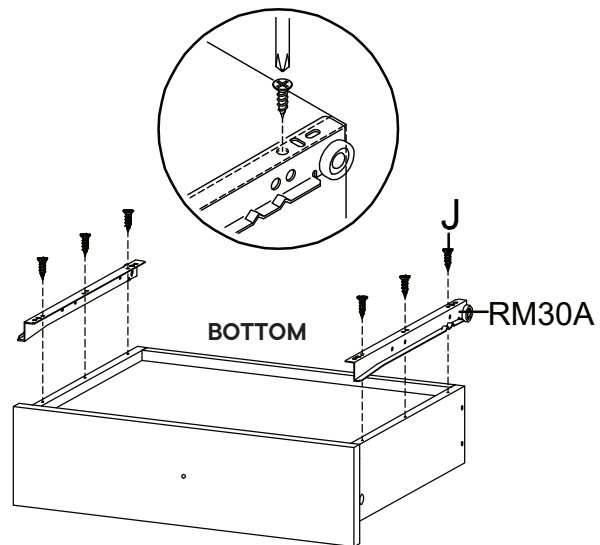

Step 8

HARDWARE

K	Handle	x1
L	Screw M 4 x 22 mm	x1

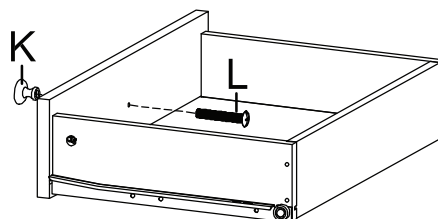

Step 9

HARDWARE

- A** Cam Bolt Ø6 x 35 mm x4
- E** Wood Dowel Ø6x30 mm x2
- H** Screw M 6 x 10.5 mm x4
- RB24A** Drawer Runner x1

COMPONENTS

- 10** Front Drawer Big x1
- 11** Side Drawer Left Big x1
- 12** Side Drawer Right Big x1

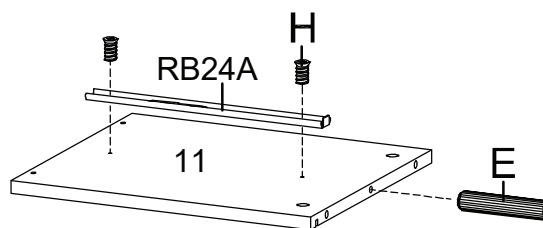
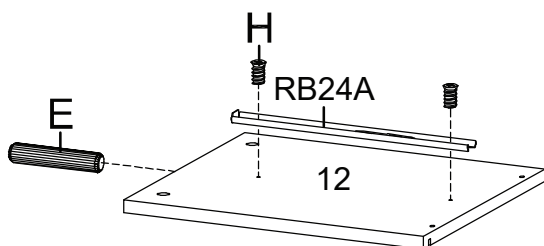
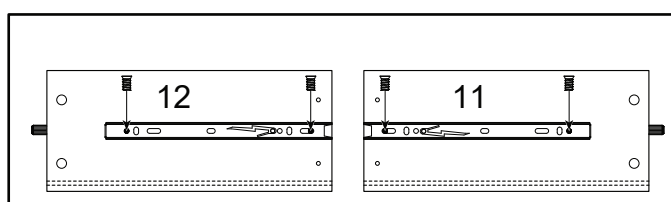
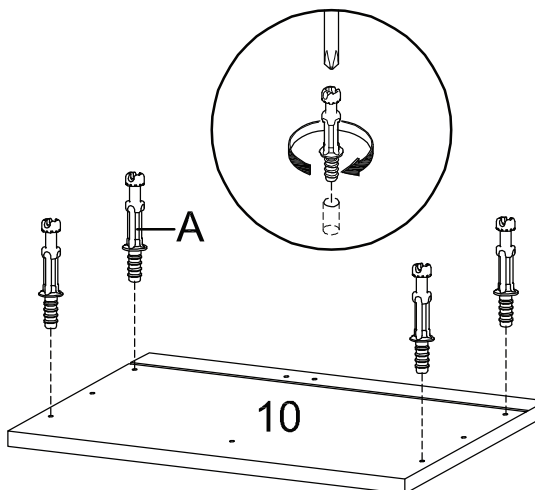

Step 10

HARDWARE

- C** Cam Lock Ø12 mm x4
- I** Screw M 8 x 39 mm x4

COMPONENTS

- 9** Bottom Drawer x1
- 10** Front Drawer Big x1
- 11** Side Drawer Left Big x1
- 12** Side Drawer Right Big x1
- 13** Back Drawer Big x1

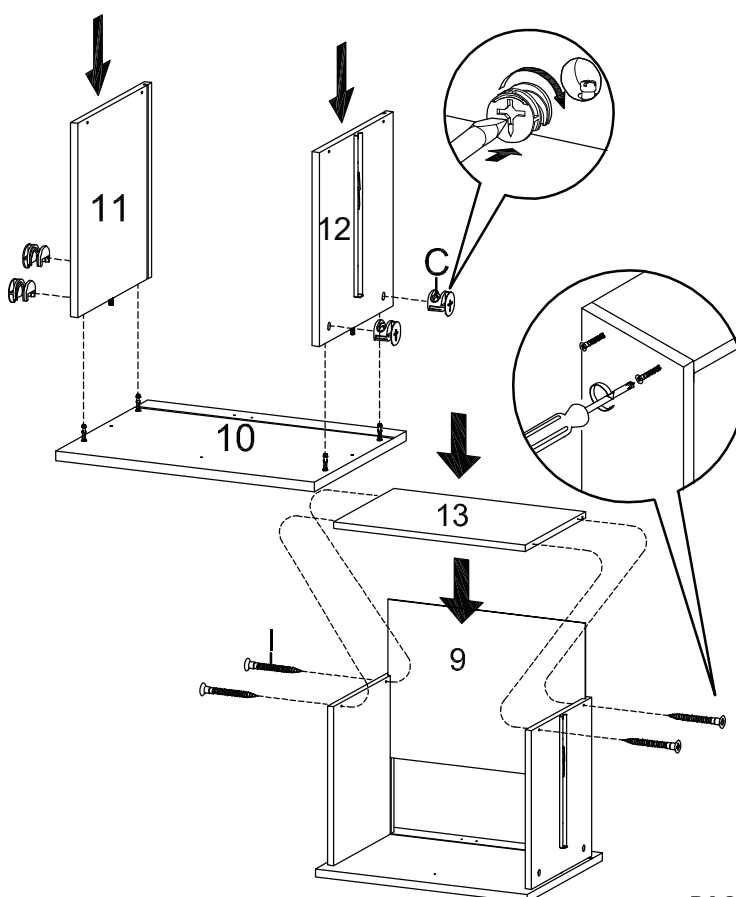

Step 11

HARDWARE

- F** Screw M 3.5 x 15 mm x4
- G** Wedge x4
- J** Screw M 3.5 x 13 mm x2
- K** Handle x1
- L** Screw M 4 x 22 mm x1
- O** Castor x1

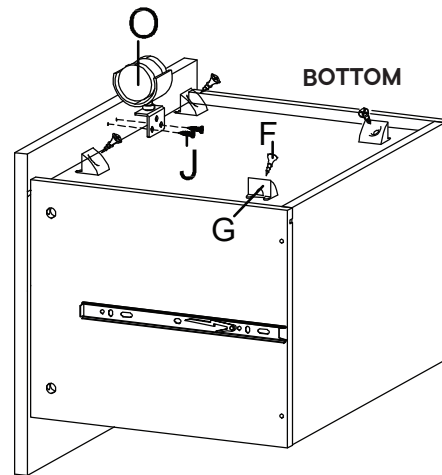
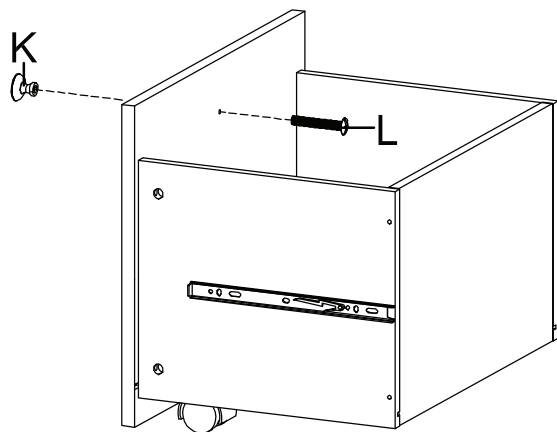
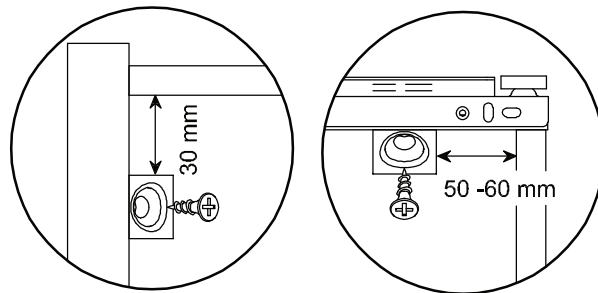

Step 12

HARDWARE

- M** File Hang Rail x2

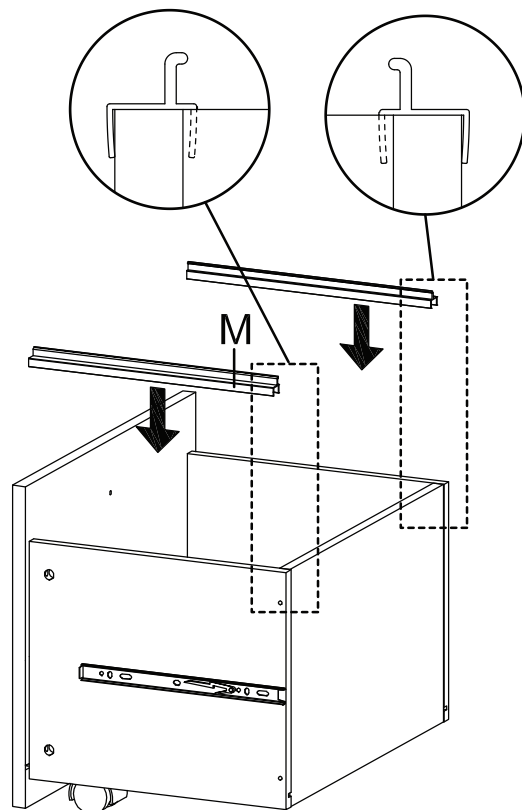

Step 13

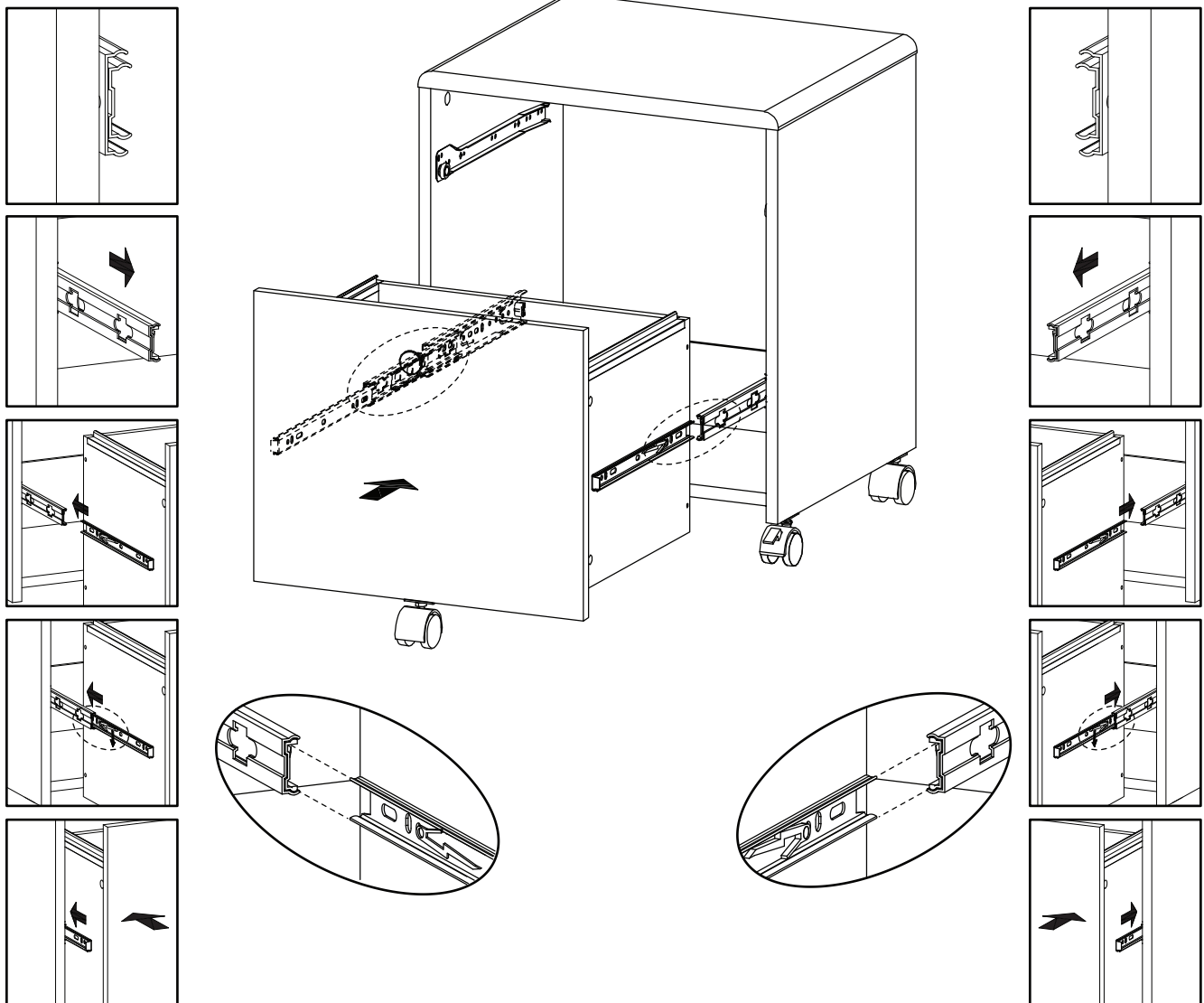

Step 14

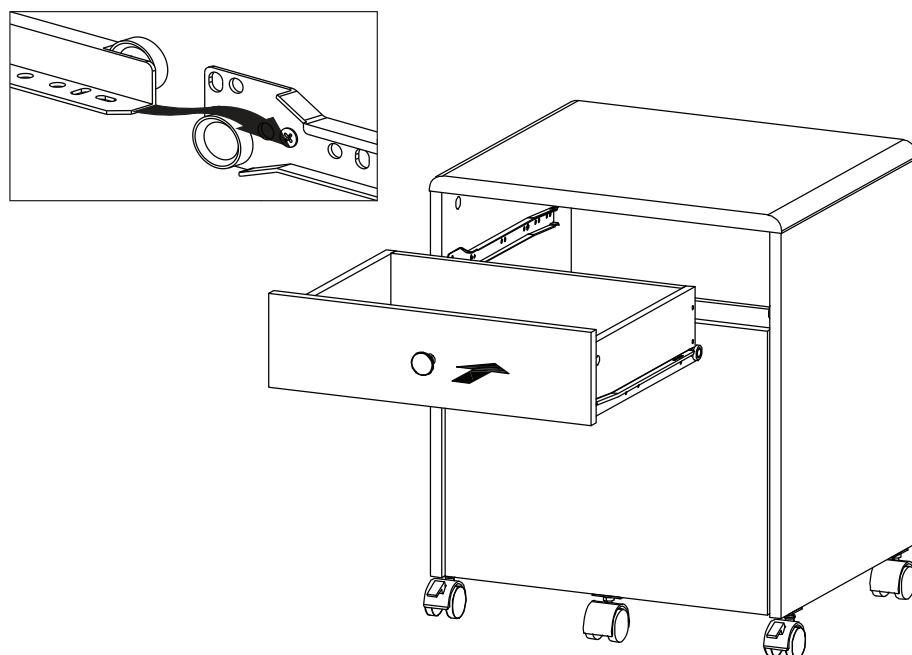

Step 15

HARDWARE

- F** Screw M 3.5 x 15.5 mm x6
- G** Wedge x6

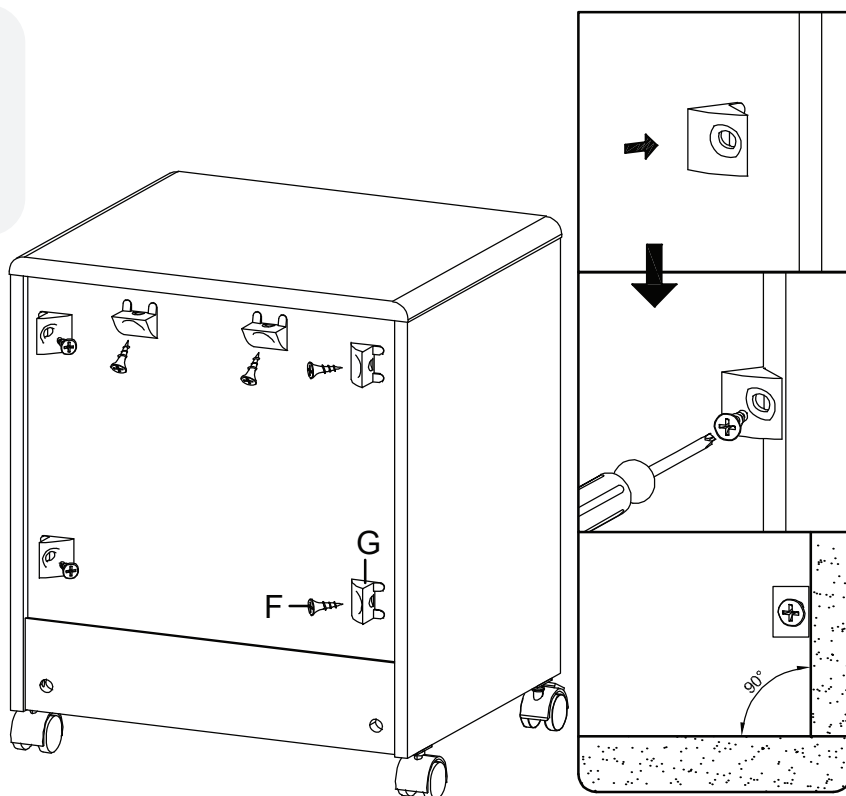

Great job!

Trolley assembly is complete

♥ CARING FOR YOUR ITEM

Indoor use only.

Not contract grade.

Clean using a non-abrasive cloth and a mild cleaner.

Never use harsh chemicals, as they could damage the finish or integrity of the item.

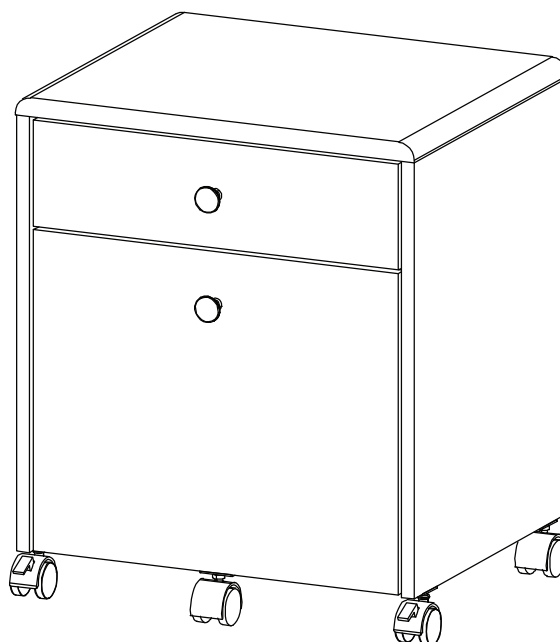

CONNECT WITH US!   

Tag us @modway_furniture and #modway for a chance to be featured.