

EEI -2922 Side Table

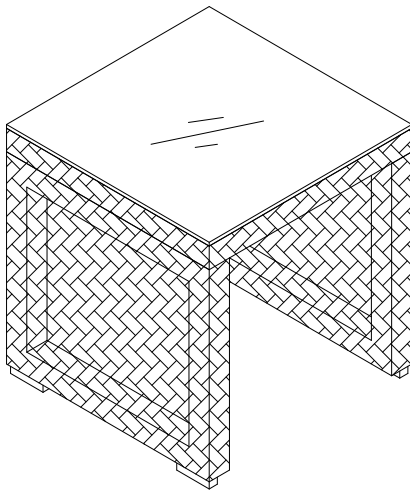

Thank you for purchasing the **MODWAY SIDE TABLE** !

Before you start, here is some helpful advice:

1. We suggest you spend a short time reading through this leaflet and then follow the simple step-by-step instructions.
2. Owing to the size and weight of the table, we recommend that it is assembled by two adults, on a carpeted or padded area, in the room that it is intended for. Approximate assembly time: 30 minutes.
3. Please do not use any tools other than those provided or recommended in these instructions.
4. Please do not throw away any of the packaging or the instruction until you have checked all the components and hardware and the furniture is fully assembled. Please ensure that the packaging is disposed of in a safe and environmentally friendly way.
5. Assemble all components loosely until advised to tighten. Depending on use, it may be necessary to tighten the components from time to time, so please save the tools that have been provided.
6. Please keep all fitting out of reach of children.



Hardware:

- | | | | |
|----|--|-----------------|-----|
| A. |  | Bolt M6x45mm | x 8 |
| B. |  | Flat Washer M6 | x 8 |
| C. |  | Allen Wrench M4 | x1 |

Component:

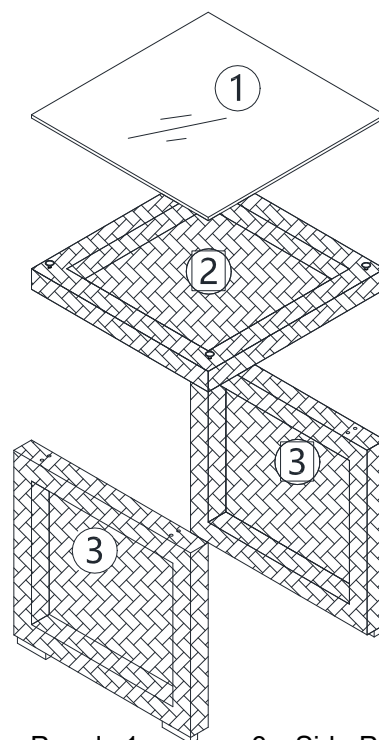

1 Glass x1

2 Top Panel x1

3 Side Panel x2

EEI -2922 Side Table

STEP 1:

Put **Top Panel (2)** on a carpeted or padded surface.

Place 2 pieces of **Side Panels (3)** to the **Top Panel (2)**.

Insert 8 pieces of **Bolts (A)** with 8 pieces of **Flat Washers (B)** into the pre-drilled holes on **Side Panels (3)**.

Use **Allen Wrench (C)** to tighten **Bolts (A)** clockwise until secure.

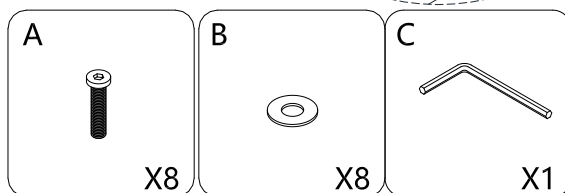
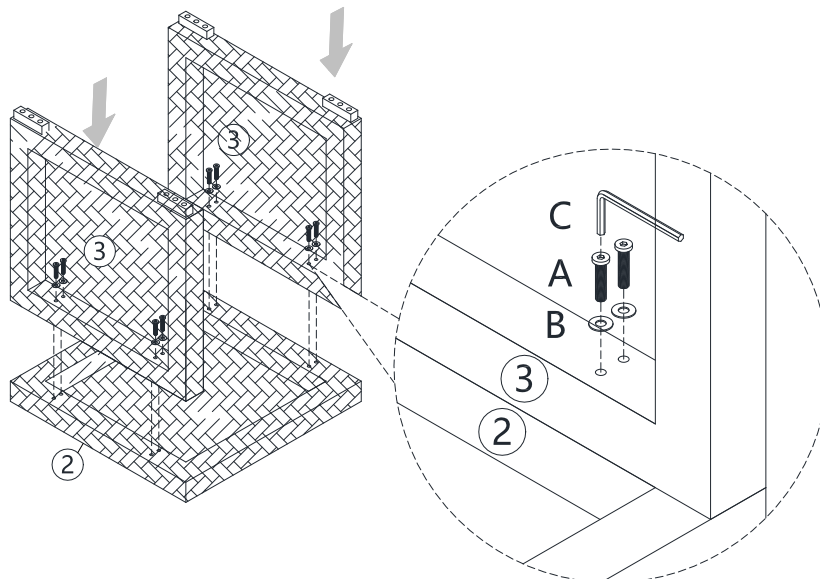

Hardware & Tools required

STEP 2:

Carefully turn over the assembled side table.

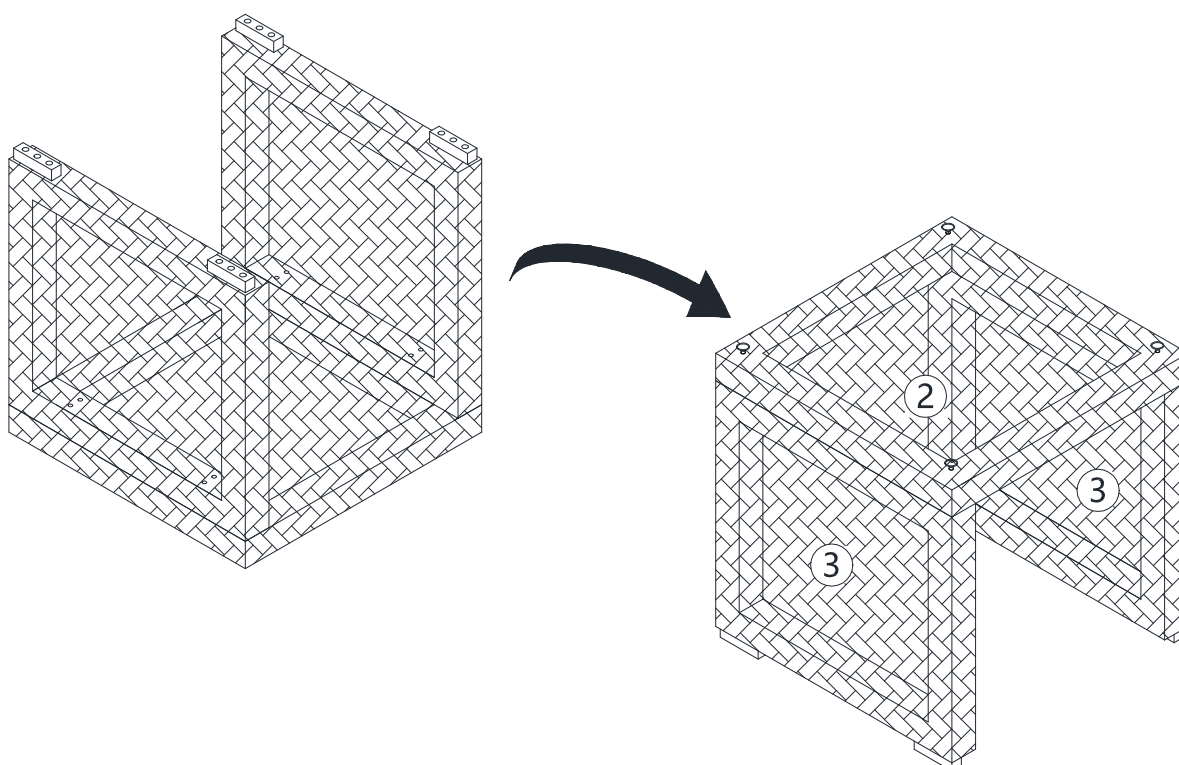

STEP 3:

Then carefully put **Glass (1)** on **Top Panel (2)**.

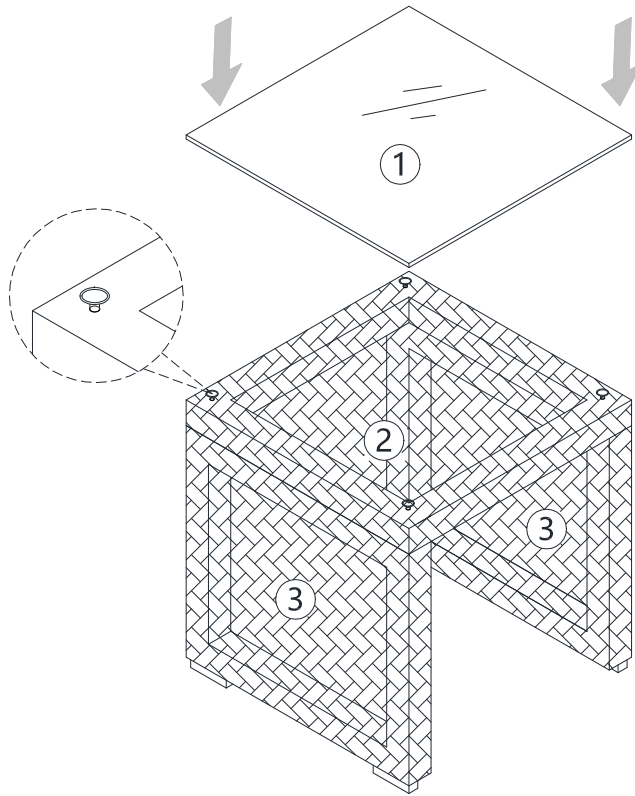

STEP 4:

Assembly is complete. Your side table is ready to be used now!

