

Thank you for purchasing the **MODWAY DINING CHAIR!**

Before you start, here is some helpful advice:

1. We suggest you spend a short time reading through this leaflet and then follow the simple step by step instructions.
2. Owing to the size and weight of the dining chair, we recommend that it is assembled by two adults, on a carpeted or padded area, in the room that it is intended for. Approximate assembly time: 30 minutes.
3. Please do not use any tools other than those provided or recommended in these instructions.
4. Please do not throw away any of the packaging or instructions until you have checked all the components and hardware and the furniture is fully assembled.
5. Assemble all components loosely until advised to tighten. Depending on use, it may be necessary to tighten the components from time to time, so please save the tools that have been provided.
6. Please keep all pieces out of reach of small children.

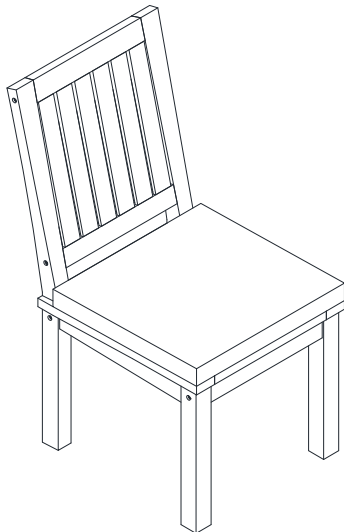

Hardware:

A  Long Bolt M6x60mm x 8

B  Allen Wrench M4 x 1

Component:

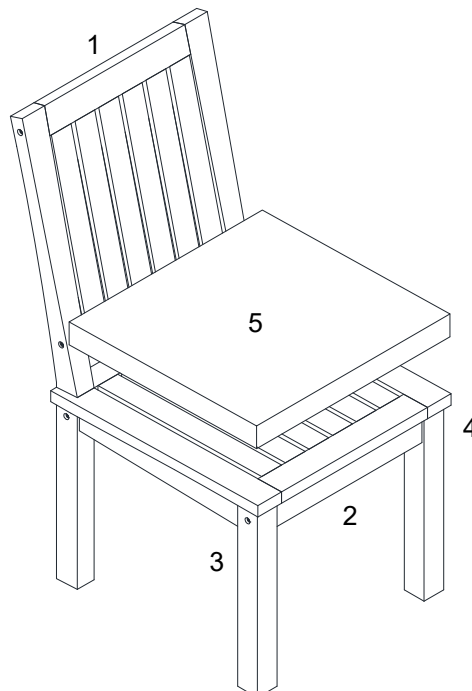

1 Chair Back x1

2 Chair Seat x1

3 Left Frame x1

4 Right Frame x1

5 Seat Cushion x1

STEP 1:

Please put **Left Frame (3)** on a carpeted or padded area.

Position **Chair Back (1)** and **Chair Seat (2)** to **Left Frame (3)**.

Insert the tenon on **Chair Seat (2)** into the rabbet on **Left Frame (3)** at first.

Then insert the tenon on **Chair Back (1)** into the rabbet on **Left Frame (3)** as shown.

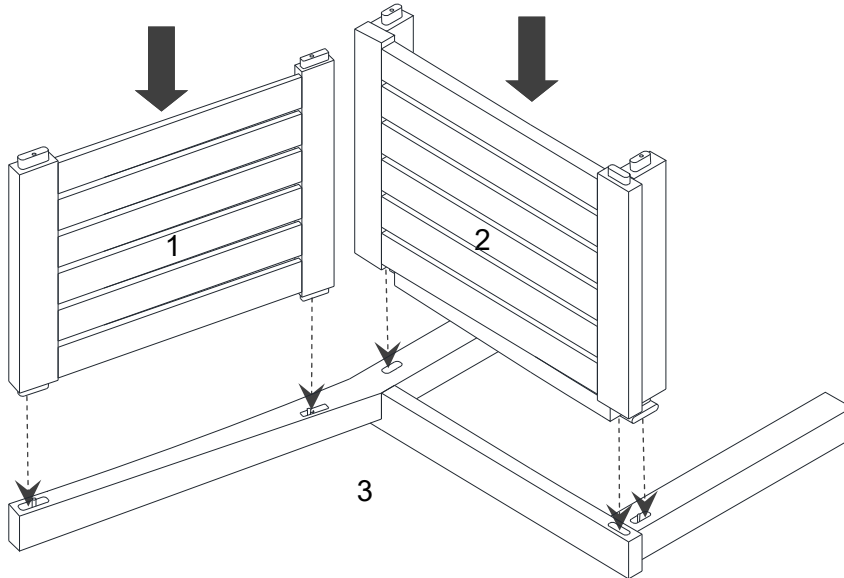

STEP 2:

Position **Right Frame (4)** to the assembled **Chair Back (1)**, **Chair Seat (2)** and **Left Frame (3)** as shown.

Insert the tenon on **Chair Seat (2)** into the rabbet on **Right Frame (4)**.

Insert the tenon on **Chair Back (1)** into the rabbet on **Right Frame (4)**.

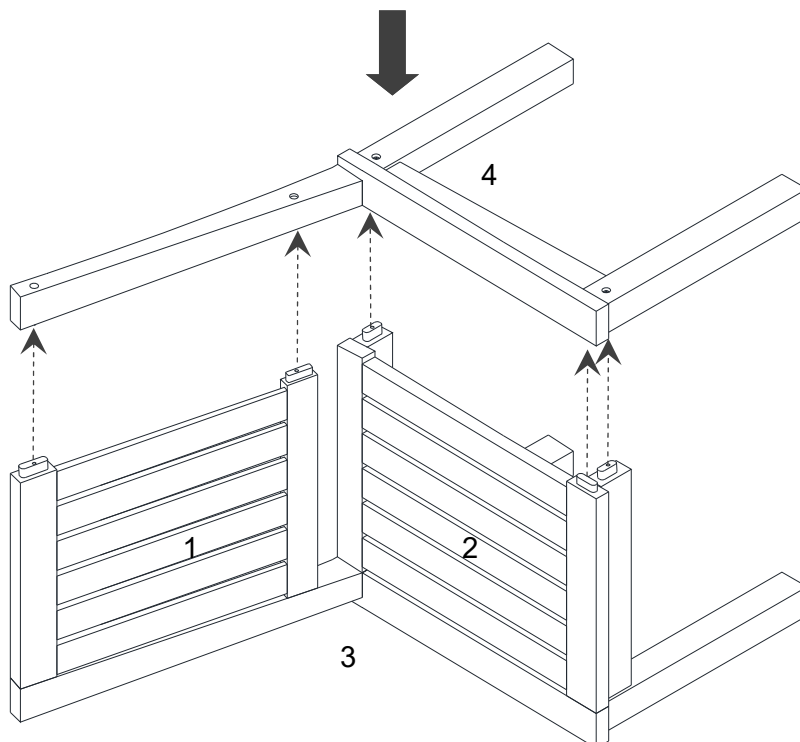

STEP 3:

Carefully turn over the assembled **Chair Back (1)**, **Chair Seat (2)**, **Left Frame (3)** and **Right Frame (4)**.



Insert 2 pieces of **Bolt (A)** into the pre-drilled holes on **Chair Back (1)** through the top pre-drilled holes on **Left Frame (3)**.

Insert 2 pieces of **Bolt (A)** into the pre-drilled holes on **Chair Seat (2)** through the top pre-drilled holes on **Left Frame (3)**.

Use **Allen Wrench (B)** to tighten **Bolts (A)** clockwise until secure.

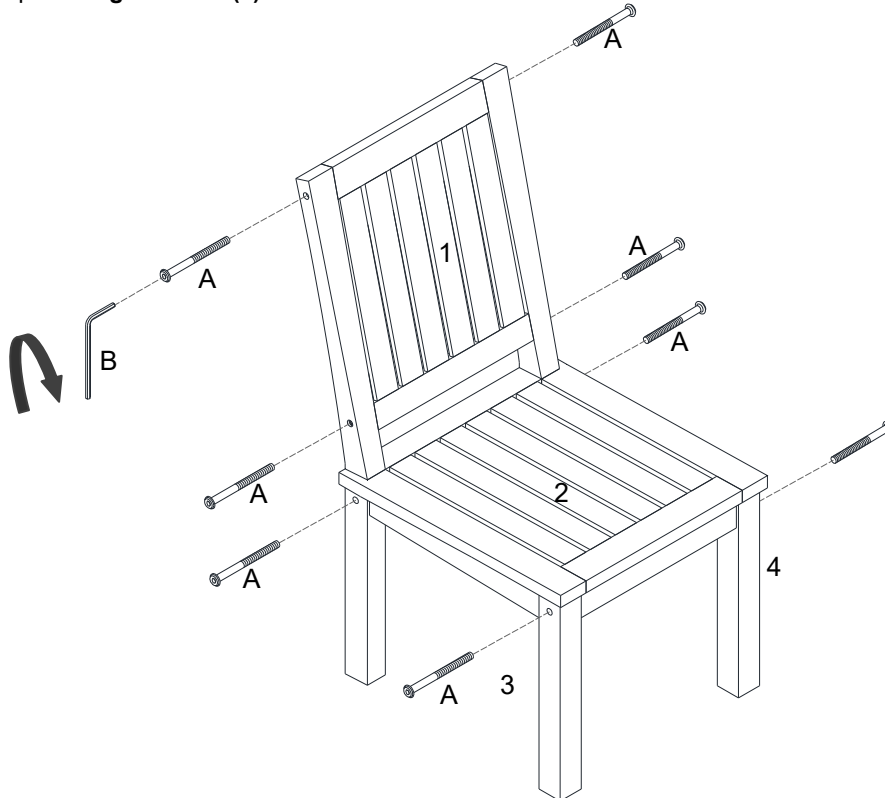
Repeat the same steps for **Right Frame (4)**.



| | |
|---|---|
|  |  |
| Ax8 | Bx1 |

Hardware & Tool required

STEP 4:

Carefully position the assembled chair to the desired location.

Put **Seat Cushion (5)** into the assembled chair.

Tie **Seat Cushion (5)** to **Chair Back (1)** by using the banding on the back of **Seat Cushion (5)** as shown.

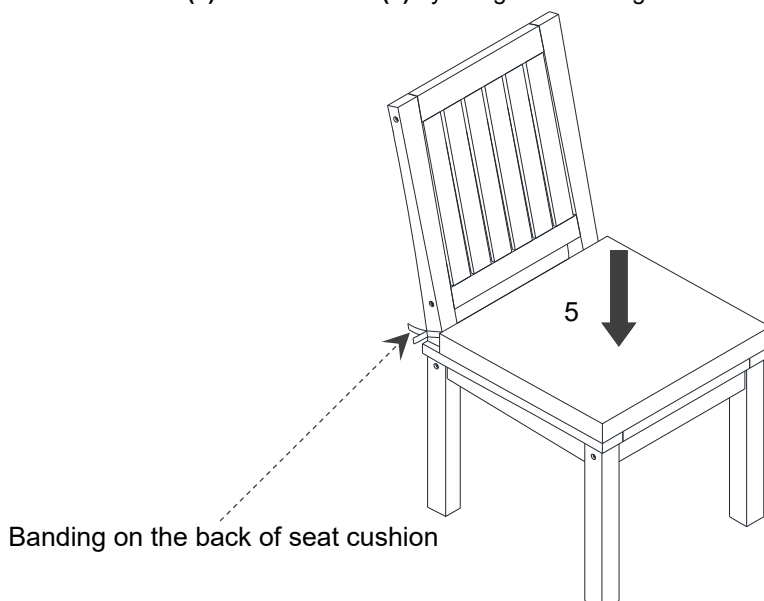

Assembly is complete. Your chair is ready to be used now!







Thank you for purchasing the **MODWAY TABLE**!

Before you start, here is some helpful advice:

1. We suggest you spend a short time reading through this leaflet and then follow the simple step by step instructions.
2. Owing to the size and weight of the table, we recommend that it is assembled by two adults, on a carpeted or padded area, in the room that it is intended for. Approx assembly time: 30 minutes.
3. Please do not use any tools other than those provided or recommended in these instructions.
4. Please do not throw away any of the packaging or the instruction until you have checked all the components and hardware and the furniture is fully assembled. Please ensure that the packaging is disposed of in a safe environmentally friendly way.
5. Assemble all components loosely until advised to tighten. Depending on use, it may be necessary to tighten the components from time to time, so please save the tools that has been provided.
6. Please keep all fitting out of reach of children.



Hardware:

| | | | |
|---|--|---------------------|----|
| A |  | Long Bolt M8x70m | x8 |
| B |  | Spring Washer M8 | x8 |
| C |  | Flat Washer M8 | x8 |
| D |  | Open Wrench M5 | x1 |
| E |  | Medial Bolt M6x60mm | x4 |
| F |  | Short Bolt M6x40mm | x2 |
| G |  | Allen Wrench M4 | x1 |

Component:

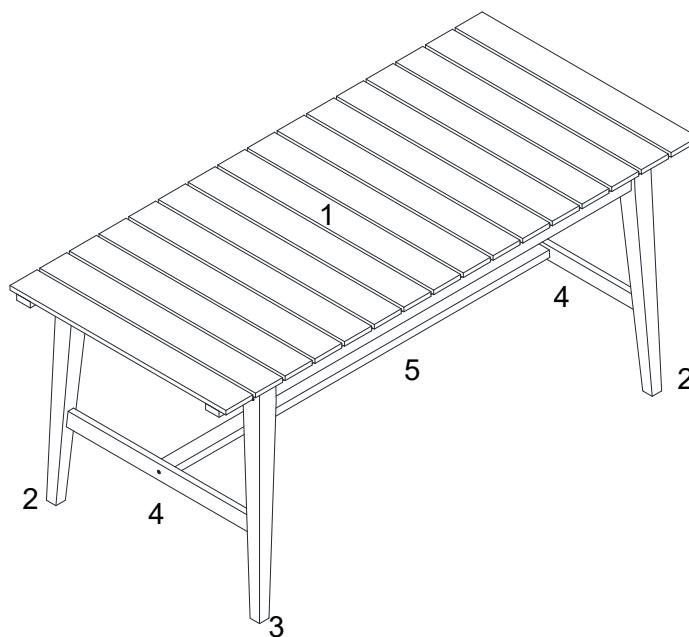

| | | | | | | | | |
|---|-----------|----|---|-------|----|---|-------------|----|
| 1 | Table Top | x1 | 2 | Leg I | x2 | 3 | Leg II | x2 |
| 4 | Stretcher | x2 | | | | 5 | Bottom Rail | x2 |

STEP 1:

Please put 1 piece of **Leg I (2)** and 1 piece of **Leg II (3)** upside down on a carpeted or padded area.

Position 1 piece of **Stretcher (4)** to the **Leg I (2)** and **Leg II (3)** as shown.

Insert the tenon on **Stretcher (4)** into the Rabbet on the **Leg I(2)** and **Leg II(3)**.

Insert 2 pieces of **Medial Bolt (E)** into the holes on **Stretcher (4)** through the holes on **Leg I (2)** and **Leg II (3)**.

Use **Allen Wrench (G)** to tighten **Medial Bolts (E)**. Do not fully tighten **Medial Bolts (E)** at this step.

Repeat the same steps for the remaining **Leg I(2)**, **Leg II(3)** and **Stretcher (4)**.

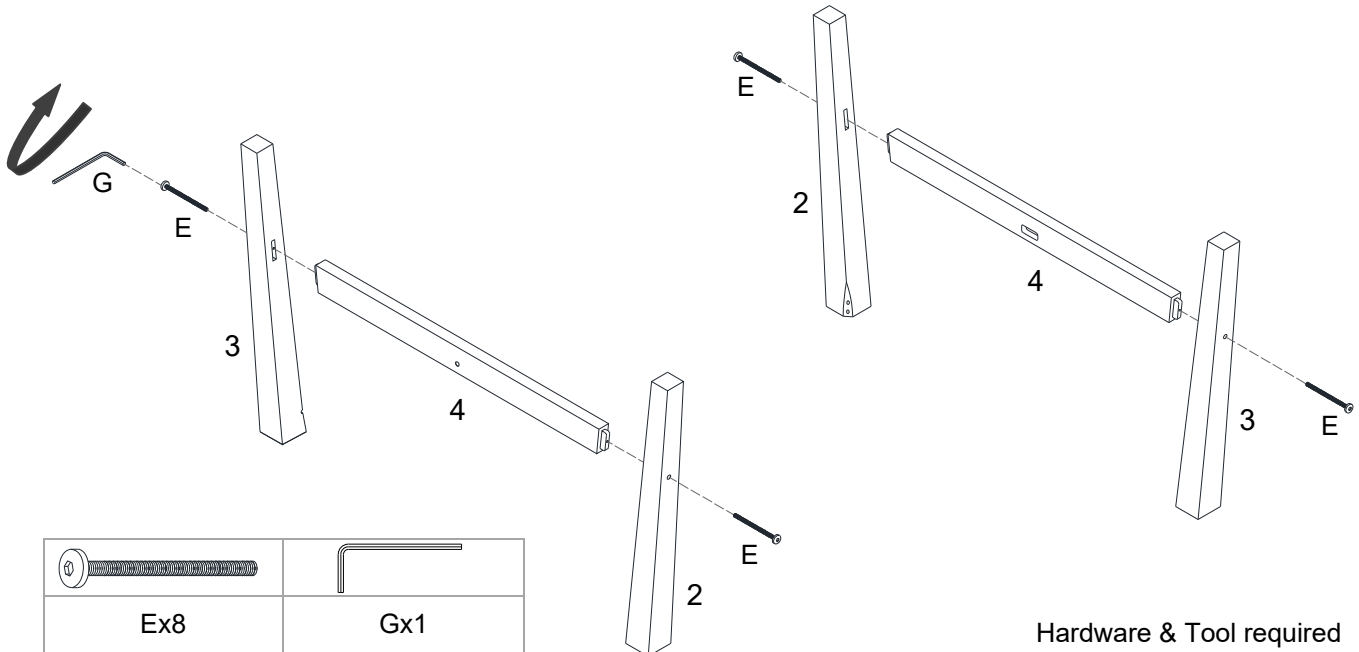

STEP 2:

Please put the **Table Top (1)** upside down on a carpeted or padded area.

Position the assembled **Leg I (2)**, **Leg II (3)** and **Stretcher (3)** into the corner of **Table Top (1)** as shown.

Insert 4 pieces of **Long Bolt (A)** with 4 pieces of **Spring Washer (B)** and 4 pieces of **Flat Washer (C)** into the pre-drilled holes on bottom of **Leg I (2)** and **Leg II (3)** through the pre-drilled holes on **Table Top (1)**.

Use **Open Wrench (D)** to tighten **Long Bolts (A)** clockwise until secure.

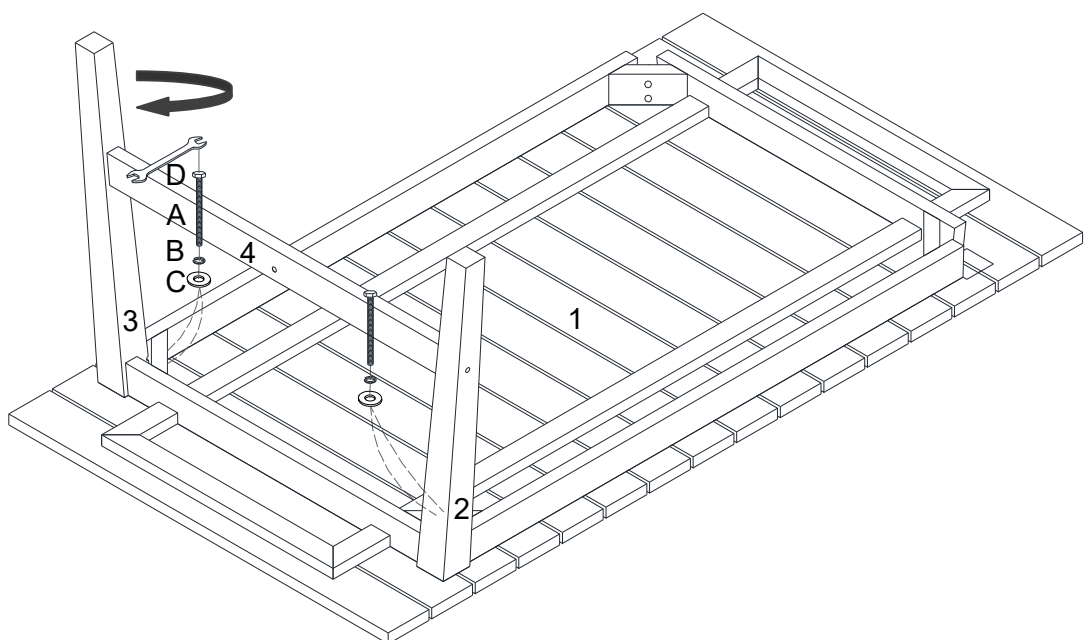

STEP 3:

Position the other sets of assembled **Leg I(2)**, **Leg II(3)** and **Stretcher (3)** into the corner of **Table Top (1)** as shown.

Insert the tenon on the end of **Bottom Rail(5)** into the rabbet of **Stretchers(4)**.

Insert 4 pieces of **Long Bolt (A)** with 4 pieces of **Spring Washer (B)** and 4 pieces of **Flat Washer (C)** into the pre-drilled holes on bottom of **Leg I(2)** and **Leg II(3)** through the pre-drilled holes on **Table Top (1)**.

Use **Open Wrench (D)** to tighten **Long Bolts (A)** clockwise until secure.

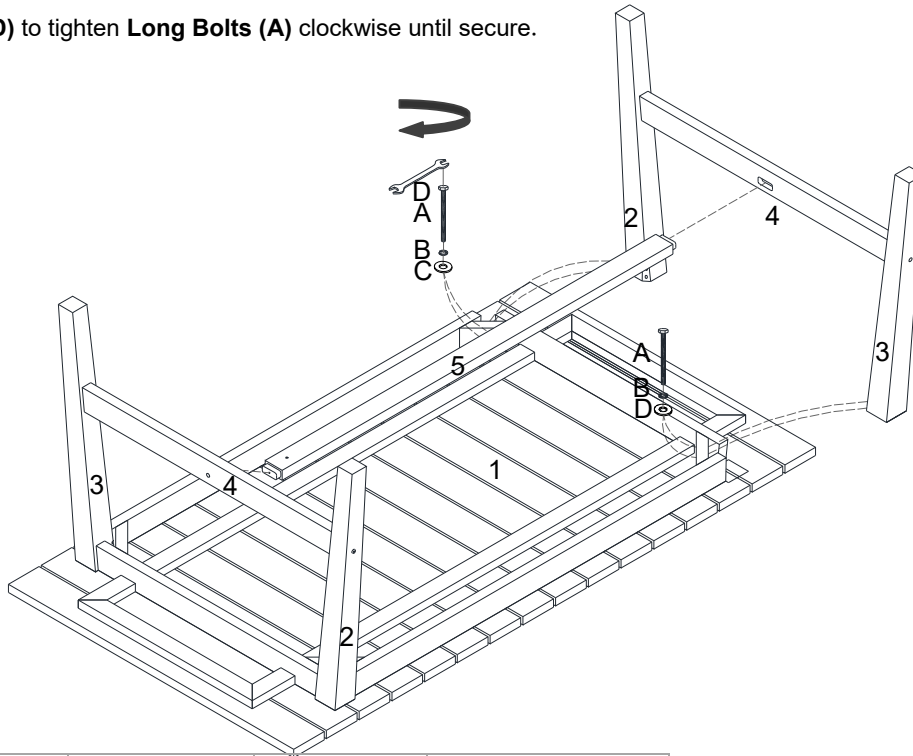

| | | | |
|-----|-----|-----|-----|
| | | | |
| Ax4 | Bx4 | Cx4 | Dx1 |

Hardware & Tool required

STEP 4:

Insert 2 pieces of **Short Bolt (F)** into the holes on **Bottom Rail (5)** through the holes on **Stretchers (4)**.

Use **Allen Wrench (G)** to tighten all the **Medial Bolts (E)** and **Short Bolts (F)**.

Use **Open Wrench (D)** to tighten all **Long Bolts (A)** clockwise until secure.

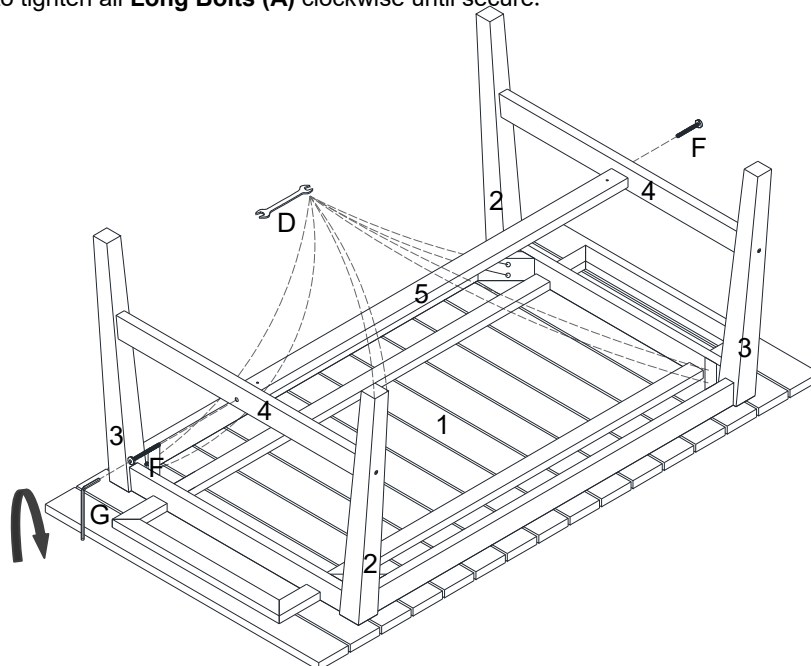

| | | |
|-----|-----|-----|
| | | |
| Dx1 | Fx2 | Gx1 |

Hardware & Tool required

STEP 5:

Carefully turn over the assembled table.



Assembly is completed. Your table is ready to be used now!