

Thank you for purchasing the **MODWAY OFFICE CHAIR**.

Before you start, here are some helpful advice:

1. We suggest you spend a short time reading through this leaflet and then follow the simple step-by-step instructions.
2. Owing to the size and weight of the chair, we recommend that it is assembled by two adults, on a carpeted or padded area, in the room that it is intended for. Approximate assembly time: 30 minutes.
3. Please do not use any tools other than those provided or recommended in these instructions.
4. Please do not throw away any of the packaging or the instruction until you have checked all the components and hardware and the furniture is fully assembled. Please ensure that the packaging is disposed of in a safe and environmentally friendly way.
5. Assemble all components loosely until advised to tighten. Depending on use, it may be necessary to tighten the components from time to time, so please save the tools that have been provided.
6. Please keep all pieces out of reach of children.

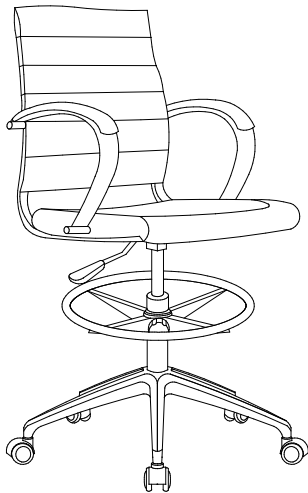

Hardware:

- | | | | |
|----|--|--------------|----|
| A. | | Bolt M8x48mm | x4 |
| B. | | Crash Pad | x4 |
| C. | | Allen Wrench | x1 |
| D. | | Cap Cover | x4 |

Components:

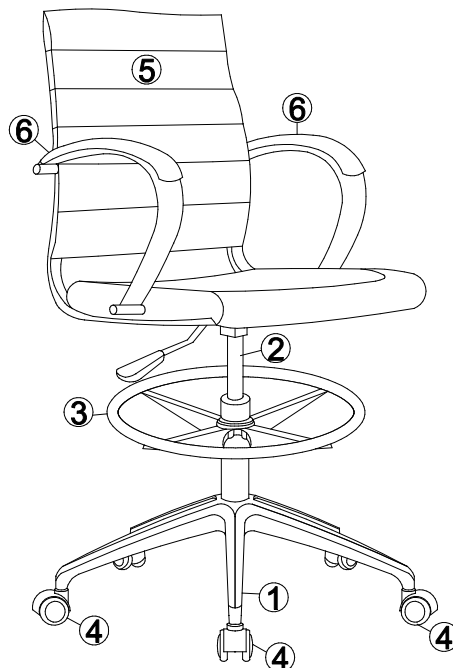

- | | | | | | |
|-----------|----|--------------------------------|----|--------------|----|
| 1. Base | x1 | 2. Cylinder Column | x1 | 3. Foot Ring | x1 |
| 4. Castor | x5 | 5. Back with Control Mechanism | x1 | 6. Arm | |

STEP 1:

1. Please put **Base (1)** on a carpeted or padded surface.
2. Insert 1 piece of **Castor (4)** into the **Base (1)** as shown by hand.
3. Repeat the same steps for the remaining 4 pieces of **Castors (4)**.

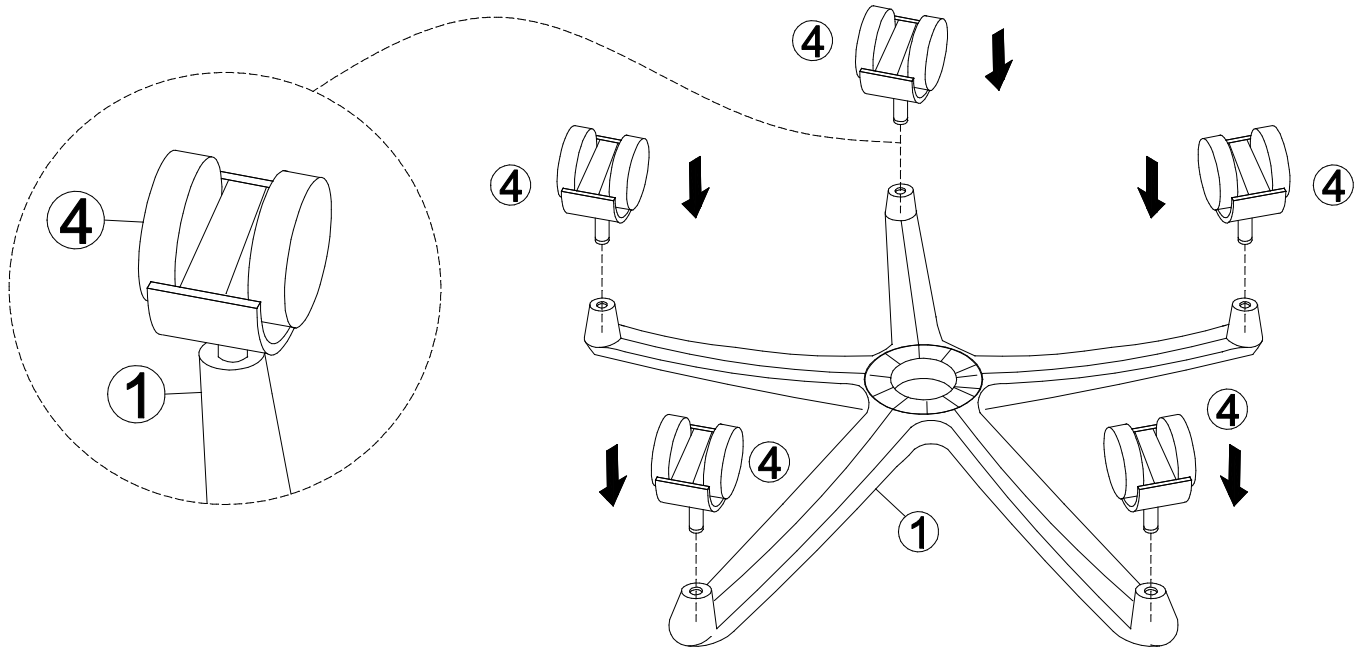

STEP 2:

1. Carefully turn over the assembled **Base (1)** from step 1.
2. Insert the **Cylinder Column (2)** as shown.

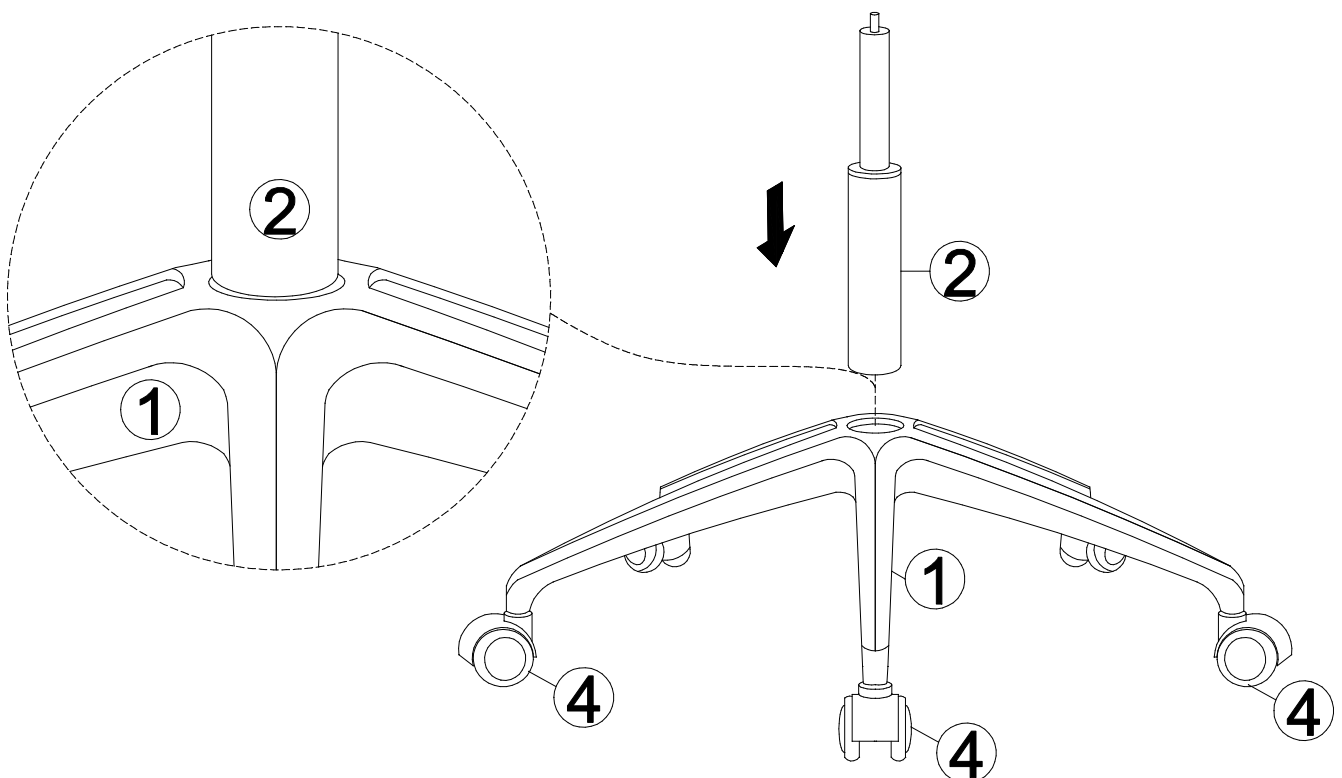

STEP 3:

1. Insert the **Foot Ring (3)** into the assembled **Cylinder Column (2)** at your desired height. But at least one inch from the top of the outer circle of **Cylinder Column (2)** as shown.
2. Please follow the shown direction of the arrow to tighten the knob by hand on the **Foot Ring (3)** until the **Foot Ring (3)** is fixed.

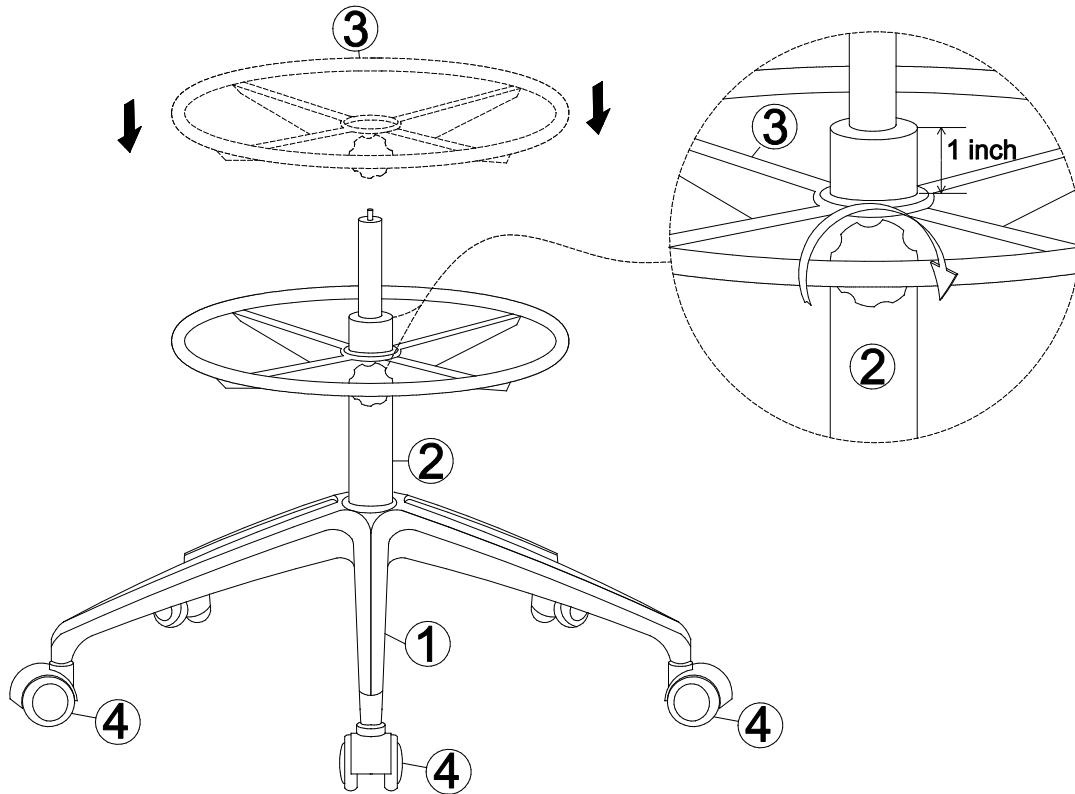

STEP 4:

1. Attach 1 piece of **Arm (6)** to the **Back with Control Mechanism (5)** by using 2 pieces of **Bolts (A)** with 2 pieces of **Crash Pads (B)** as shown, Tighten **Bolts (A)** by using **Allen Wrench (C)** and attach 2 pieces of **Cap Covers (D)** to the holes on **Arm (6)** by hand as shown.
2. Repeat the same steps for another **Arm (6)**.

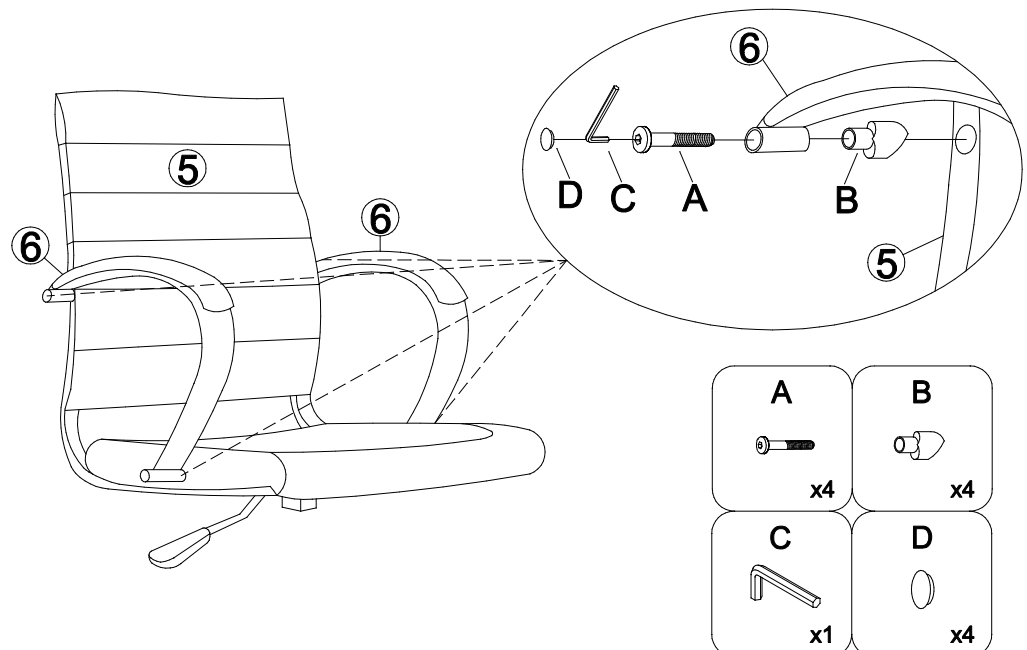

Hardware & Tools Required

STEP 5:

1. Insert **Back with Control Mechanism (5)** into the **Cylinder Column (2)** as shown.
2. Assembly is complete. Your office chair is ready to be used now!

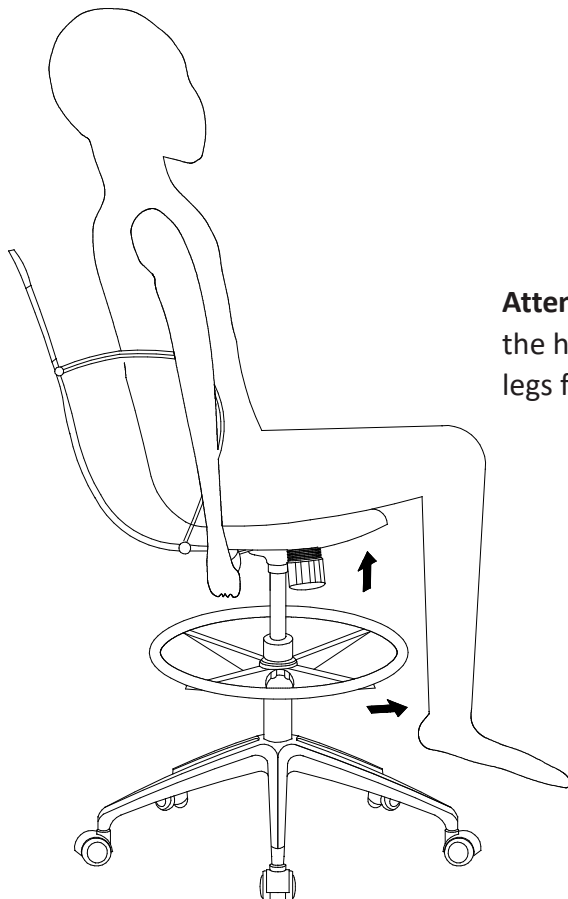
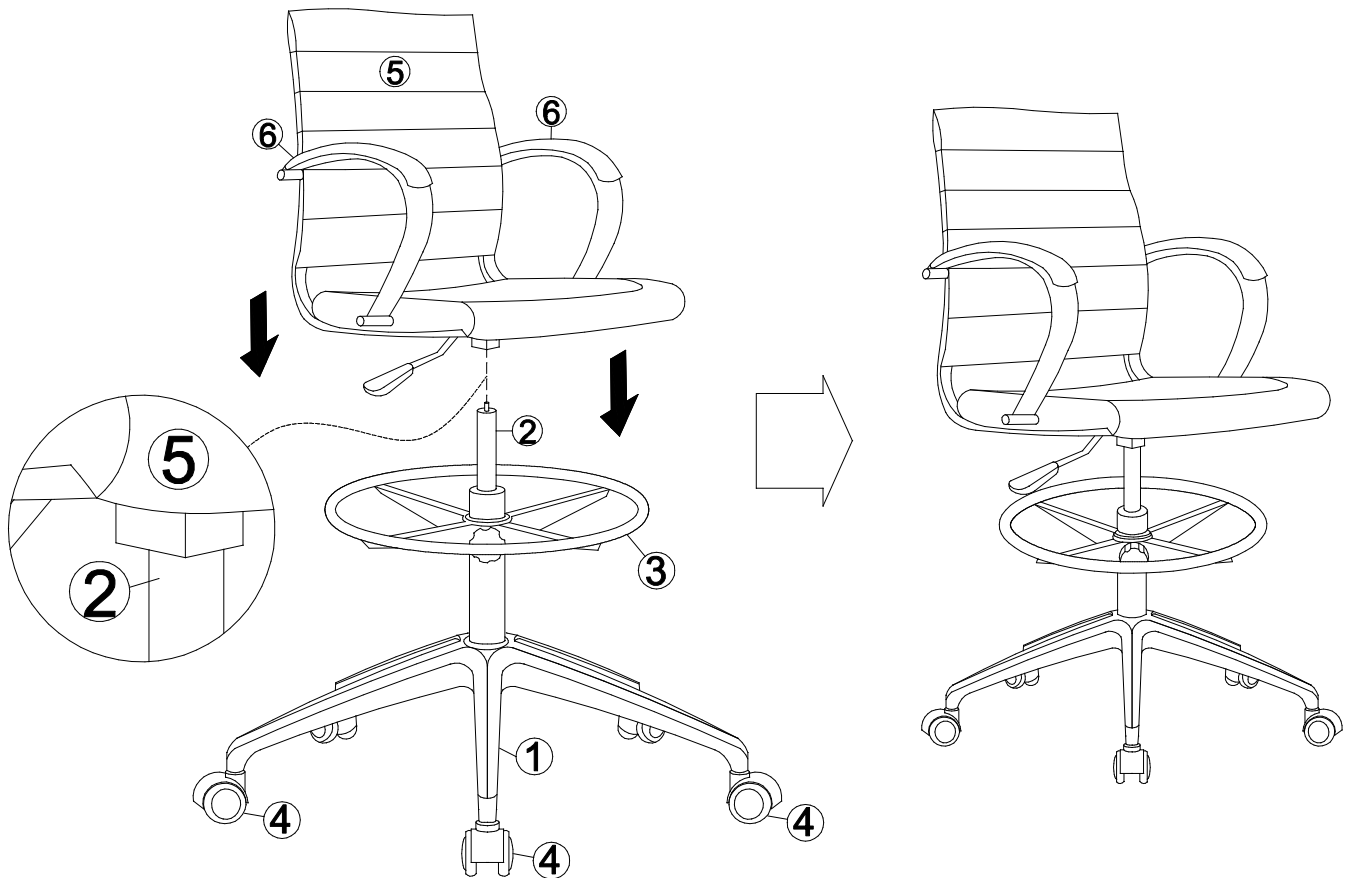

Attention: When you use the handle to adjust the height to be lower, please move away your legs from the foot ring at the same time.